

Soulet

FUN SINCE 1846

NOTICES – MANUAL – NOTICIA



Cerland
236, Avenue Clément Ader
59118 Wambrechies
FRANCE
www.soulet.com

505553 ISIS

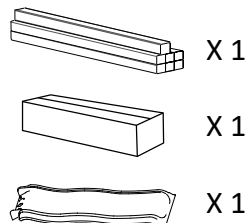

4 h



Tutorial



Madame, Monsieur,

Ce produit a été conçu et fabriqué en respectant les exigences de la directive européenne 2009/48/CE relative à la sécurité des jouets. Le respect de ces exigences a été vérifié, en application des normes jouet EN 71 parties 1, 2, 3 et 8 ainsi que du règlement 1907/2006/CE (REACH), par un laboratoire indépendant. Toutes les informations figurant dans cette notice sont imposées par cette réglementation. Il vous appartient de respecter ces instructions pour permettre à vos enfants d'utiliser ce produit avec le maximum de sécurité.

CONSIGNES DE MONTAGE

- Ce produit est à assembler par vos soins.
- Attention. Assemblage par un adulte requis.
- Attention. Petits éléments : Danger d'étouffement. Pendant le montage, tenir les petits enfants éloignés.
- Conservez impérativement cette notice pour vous y référer en cas de besoin, notamment pour : les opérations d'entretien ultérieures, l'identification des composants par le Service Après Vente.
- Les agrès et/ou toute pièce défectueuse doivent être remplacés exclusivement par une pièce fournie par notre SAV ou revendeur agréé.
- Pièces détachées disponibles pendant 2 ans à compter de la date de facturation du produit.
- Ne pas modifier la disposition des agrès. Le produit ne doit pas être modifié, risque de blessure grave.
- Le non respect des instructions détaillées dans cette notice entrainera une utilisation dangereuse accompagnée de dangers de chute et/ou de choc.
- Les accidents consécutifs à une utilisation en dehors des prescriptions reprises dans cette notice dérogent toutes responsabilités du fabricant.
- Les emballages ne sont pas des jouets, ne laissez pas les enfants jouer avec. Ne jetez pas les emballages dans la nature. Respectez les consignes de recyclage.
- Avant l'assemblage, assurez-vous que :
 - 1 - la zone où le produit sera monté est : -plane et horizontale -Située à deux mètres minimum de tout objet, structure ou obstacle (haie, arbre, fil à linge, câble électrique...) susceptible de blesser l'utilisateur du produit. -sa surface ne doit pas être dure (asphalte, béton...), privilégiez la pelouse ou un terrain meuble (sable, matériaux amortissant...)
 - 2 - la visserie est complète. Garder les composants supplémentaires, ils pourront vous être utiles lors des opérations d'entretien ultérieures.
- Nous vous recommandons de ne pas orienter la glissière de toboggan face au soleil.
- Après l'assemblage :
 - poncer manuellement et à l'aide d'un papier abrasif les composants bois pour éliminer les éventuelles échardes apparues pendant le montage du produit.
 - Régler (suivant le schéma Y) les agrès qui le nécessitent. Vérifier la distance entre le dessous de l'agrès et le sol. Cette distance permet de sécuriser l'utilisation du portique. Si elles sont inférieures à celles indiquées dans la figure W, utilisez les anneaux plastiques pour ajuster la hauteur du siège. En cas d'impossibilité contactez notre SAV.

CONSIGNE DE SÉCURITÉ D'UTILISATION

- Attention. Ce produit est destiné :
 - à un usage familial en extérieur. Il n'est pas destiné à un usage dans les aires de jeux collectives qu'elles soient : privées (hôtels, gîtes, camping, casernes, établissement recevant du public...) ou publiques (aires de jeux des écoles, jardins ou parc des municipalités).
 - aux enfants de 3 à 12 ans d'un poids maxi de 50 kg (Sauf siège bébé : destiné uniquement à un enfant de 6 à 24 mois d'un poids maxi de 15 kg). Ce poids maxi est ramené à 35 kg par assise dans le cas des agrès à assise double (vis-à-vis et balancelle).
- Attention. Ne convient pas aux enfants de moins de 36 mois. Agrès inadaptés. Danger de chute.
- Attention. À utiliser sous la surveillance d'un adulte. L'utilisation de ce jouet doit se faire obligatoirement sous la supervision d'un adulte qui doit s'assurer :
 - que les enfants utilisant le jouet ont l'âge et l'habileté nécessaire pour le faire.
 - qu'il n'y a qu'un seul enfant par assise - qu'aucun enfant ne se situe dans les zones d'oscillation des agrès : danger de chocs - qu'aucun enfant n'utilise le produit de manière inadaptée et/ou dangereuse : dangers de blessure grave.

MAINTENANCE

- Pour éviter que votre produit présente un danger au cours de son utilisation nous vous demandons de vérifier tous les mois :
 - Les crochets de suspension et les paliers articulations. Les changer s'ils présentent une usure supérieure à 10% de l'épaisseur d'origine.
 - Témoin d'usure : dès l'apparition de la partie métallique, au niveau de l'anneau plastique, il est impératif de changer l'ensemble de l'agrès.
 - Le serrage de chaque vis et écrou : les resserrer si nécessaire.
 - La résistance des ancrages au sol. - La présence des capuchons sur les écrous : s'ils sont absents les remplacer par des écrous et/ou capuchons identiques.
 - L'état des plastiques (assises, repose-pieds, glissière...) Les changer s'ils sont fendus ou percés.
 - Les assises, cordes et autres dispositifs de fixation à la recherche d'éventuels signes de dégradations.
 - L'apparition des échardes sur les composants en bois, les poncer si nécessaire.
- Pendant la période hivernale et pour éviter les dégradations dues aux intempéries, ranger les agrès à l'abri (garage, cave...).
- Selon la zone géographique (bord de mer...), certains revêtements peuvent s'abimer. En cas d'apparition de tache de rouille sur les parties métalliques, les traiter avec un produit adapté. Si la corrosion continue de se développer, contacter le SAV.
- Graisser toutes les parties mobiles métalliques. Si les agrès grincent, enduisez les crochets d'un lubrifiant adapté sous forme de gel. Ne pas utiliser de graisse liquide.
- Surveillez l'état du sol sur lequel le produit est installé, retirer les cailloux et autres objets susceptibles de blesser les utilisateurs en cas de chute.
- Attention. Tenir loin du feu. Les tissus doivent être nettoyés à l'aide d'une éponge humide. Ne pas utiliser de produits lessiviels.

INFOS BOIS : NORMES, QUALITÉ ET ESTHÉTISME DU BOIS

• Tous les composants en bois sont traités à cœur par procédé autoclave. Ce procédé consiste à extraire par le vide l'intégralité de l'humidité contenu dans le bois. Le produit de cure est ensuite injecté sous pression. Il pénètre au cœur du bois en s'y fixant définitivement. Ce procédé est certifié CTB+. Il garantit la préservation endant 5 ans.

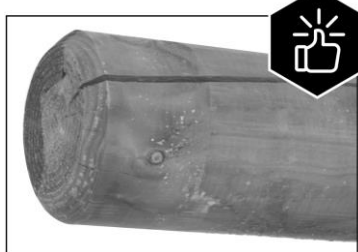

- Les bois recoupés ou reperçés après le procédé autoclave doivent impérativement être badigeonnés avec un produit de traitement complémentaire.
- Le bois est un matériau fibreux, les variations de température et d'humidité peuvent provoquer des fentes longitudinales. Ces fissures n'altèrent pas la résistance mécanique du composant car elles sont dans le sens des fibres du bois. Par conséquent les fentes n'entrent pas dans le cadre de la garantie.
- Lorsque le bois est humide, il peut se former une pellicule noirâtre. Quand cette pellicule est sèche, brossez-la pour la faire disparaître.
- Selon le degré d'humidité de l'air, le diamètre des rondins en bois peut augmenter (air très humide) ou diminuer (air très sec), la tolérance des diamètres intérieurs des angles de liaison prend en compte ces phénomènes. Le jeu entre le rondin et l'angle peut, dans certain cas, atteindre plusieurs millimètres : n'intercaler aucun produits (cale, mastic, pate à bois,...) dans cet espace libre.

SERVICE APRES VENTE et INFOS NORMES :

soulet.zendesck.com

Soulet
FUND SINCE 1846

NON FOURNIS / NOT INCLUDED

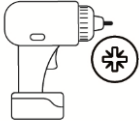







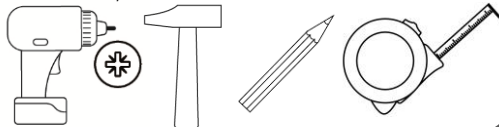



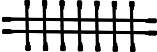

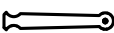
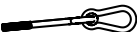



5553 - ISIS

(Pi)	 90x90x2000 mm	Ref : S54756	1
(Pj)	 70x70x300 mm	Ref : S54760	8
(Tch)	 70x34x283 mm	Ref : S54779	8
(Tci)	 70x34x428 mm	Ref : S54780	8
(Tcj)	 70x34x120 mm	Ref : S55960	2
(Tck)	 70x34x455 mm	Ref : S55959	4
(Tcn)	 70x34x800 mm	Ref : S55963	3
(Lbe)	 90x22x800 mm	Ref : S55964	10
(Lbr)	 90x22x800 mm	Ref : S53925	1
(Tbt)	 46x28x580 mm	Ref : S54123	5
(Lbl)	 100x16x552 mm	Ref : S54777	2
(Lbm)	 100x16x676 mm	Ref : S54774	2
(Lbn)	 100x16x800 mm	Ref : S54775	2
(Lbo)	 100x16x926 mm	Ref : S54776	2
(Lbp)	 100x16x1050 mm	Ref : S54777	2
(Lca)	 100x16x515 mm	Ref : S56490	2
(Lcb)	 100x16x435 mm	Ref : S56491	9
(Lbj)	 100x22x1180 mm	Ref : S54772	2

NON FOURNIS / NOT INCLUDED



Tcp	 42x42x90mm	Ref : S04778	3
Abs	 x 1 50 kg max	Ref : S04734	2
Abn		Ref : S05965	1
Aaf		Ref : S05941	10
Abt		Ref : S04751	1
Qe		Ref : S04855	4
Qg		Ref : S04095	4
Vaf	 Ø5x45 mm		144
Vu	 Ø5x30 mm		2
Vag	 Ø6x60 mm		100
Vaj	 Ø10x30 mm		10
Vai			10
Vaz	 Ø6x100 mm		12
Vau	 Ø8x80 mm		12
Val	 M12		8
Vam	 M12		8
Van	 M12		6
Vap	 M12x160 mm		2

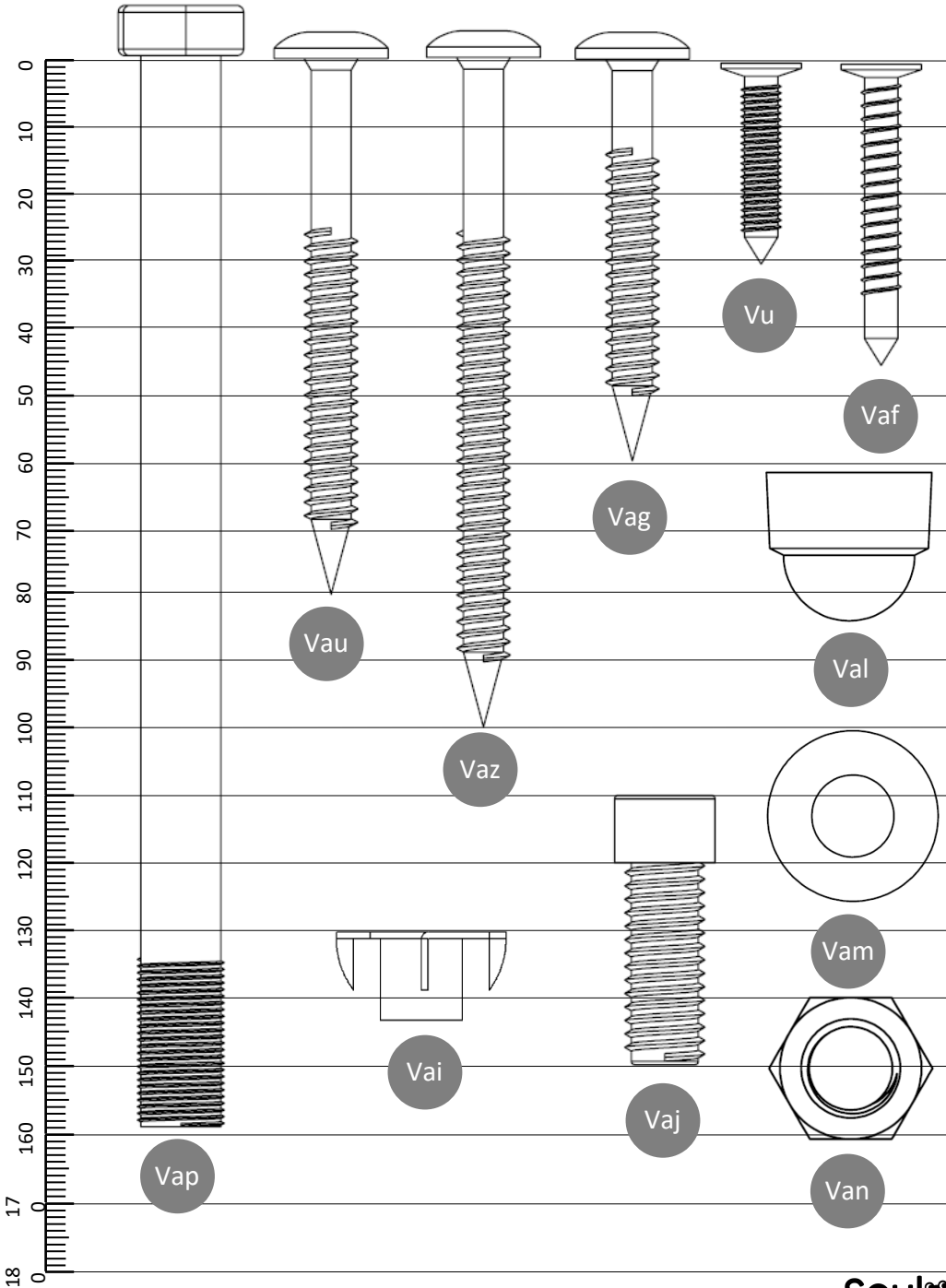

505553 - ISIS

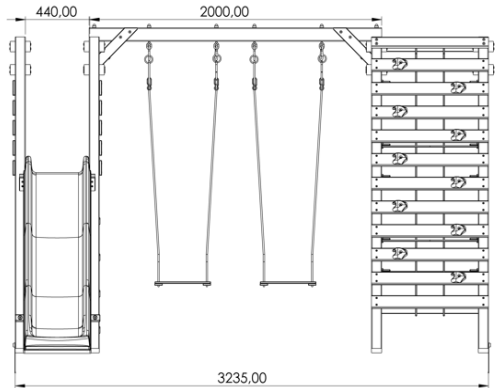
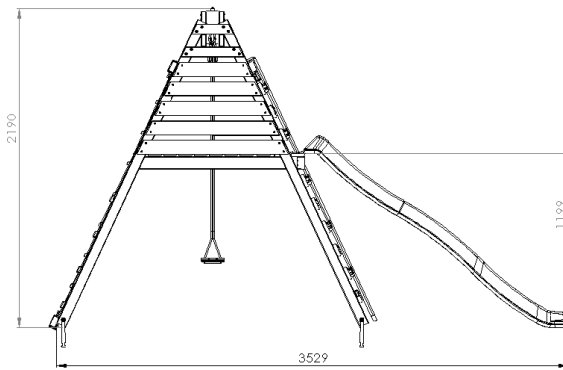

FR -les cotes ci-dessus sont indicatives, elles peuvent varier selon la méthode de montage.

EN -Above dimensions are indicative, they can varied according to the assembly method.

DE -Die oben angegebenen Maßangaben sind unverbindlich. Sie können je nach Aufbauverfahren abweichen.

ES -Las dimensiones más arriba son indicativas, pueden variar según el método de montaje.

IT -Le dimensioni sono indicative, possono variare secondo il metodo di montaggio.

PT -As dimensões acima são indicativas, podem variar de acordo com o método de montagem.

NL -De hierboven opgegeven afmetingen zijn indicatief, zij kunnen afwijken naargelang de manier van montage.

PL -Powyższe wartości są orientacyjne, mogą się różnić w zależności od metody montażu

HU -A fenti értékelések indikativak, a szerelési módtól függoen változhatnak

SK -Vyššie uvedené rozmery sú orientačné, môžu sa meniť podľa spôsobu montáže.

CZ -Výše uvedené rozměry jsou pouze orientační, mohou se lišit podle způsobu montáže.

HR -Gore navedene dimenzije su indikativne, mogu se razlikovati ovisno o načinu montaže.

EL -Οι παρακάτω διαστάσεις είναι ενδεικτικές, μπορεί να διαφέρουν αναλόγως της μεθόδου εγκατάστασης.

SL -Zgornje mere so okvirne, lahko se razlikujejo glede na način pritrditve.

BG -Горните размери са ориентировъчни, те могат да варират в зависимост от метода на монтажа.

RO -Dimensiunile de mai sus sunt orientative, acestea pot varia în funcție de metoda de montare.

1



Pi x 1



Van x 4



Val x 4



Qg x 4



Vam x 4

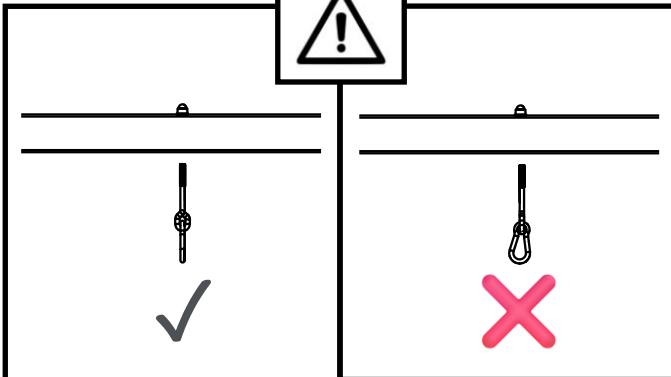
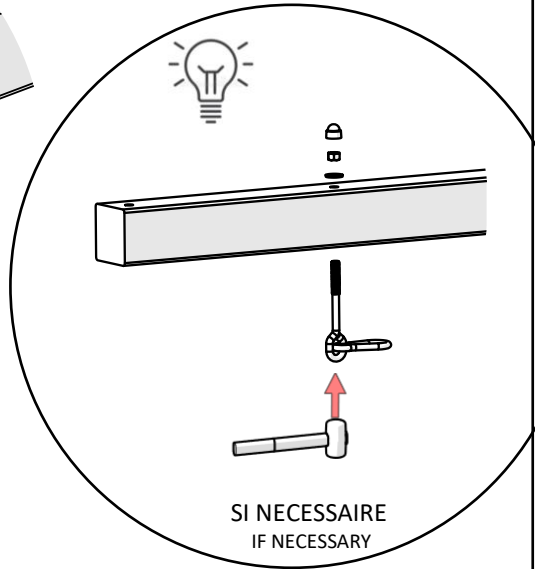
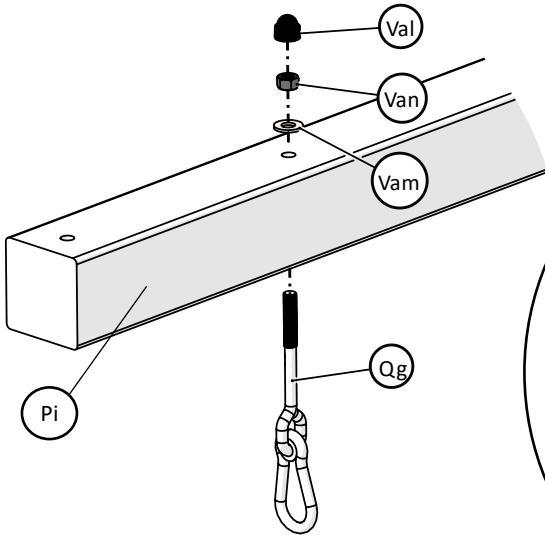
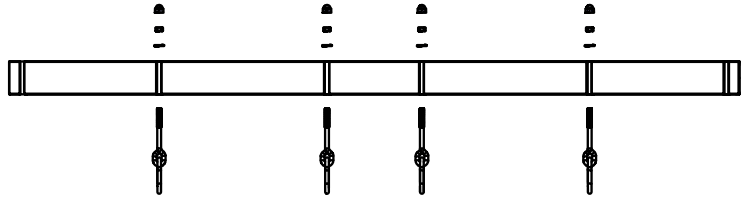
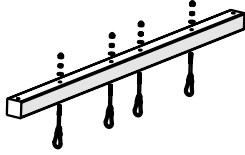

2



Pj x 4

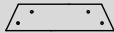

Tch x 4



Vag x 8

Ø6x60 mm

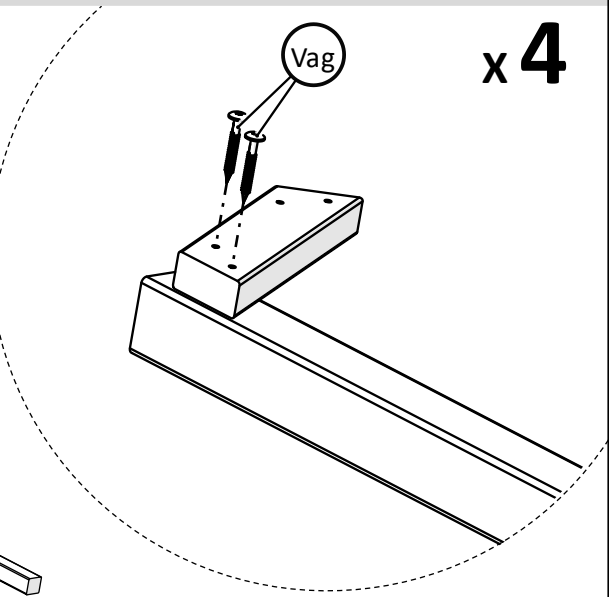
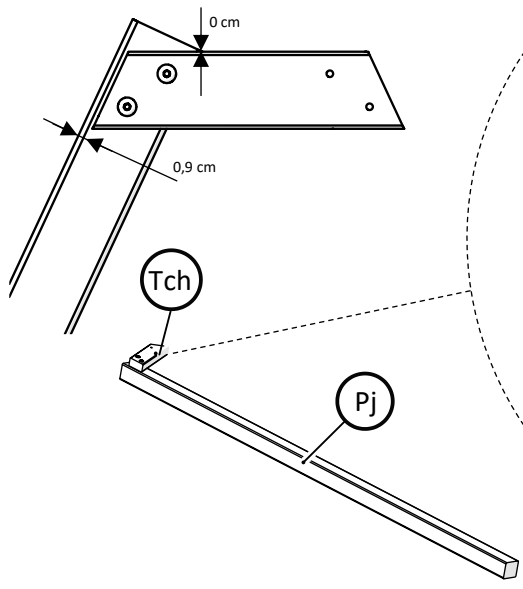

x 4

3



Pj x 4



Vag x 8

Ø6x60 mm

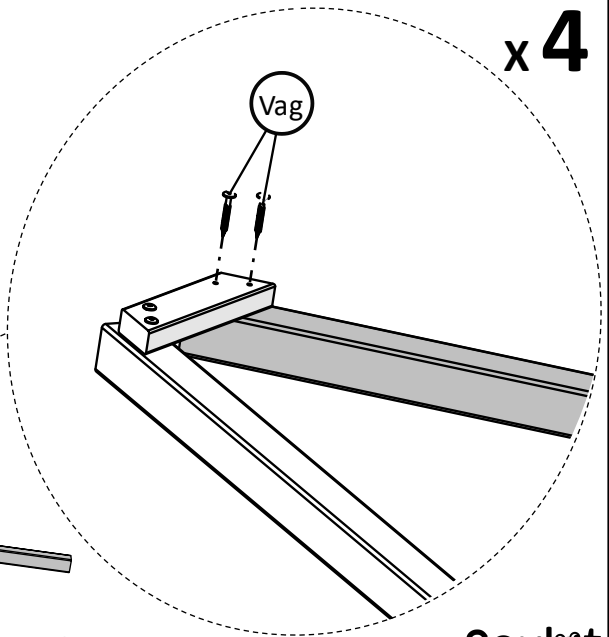
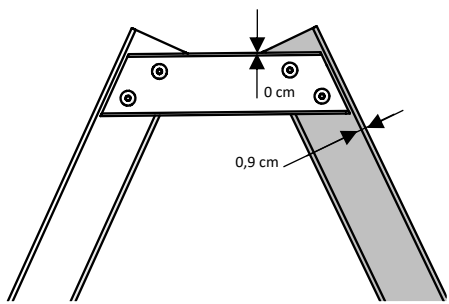

x 4

4

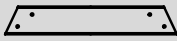

Tci x 4



Vag x 16

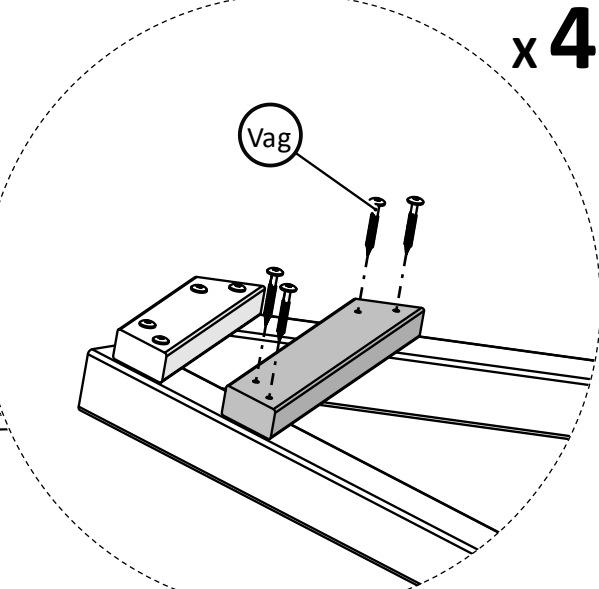
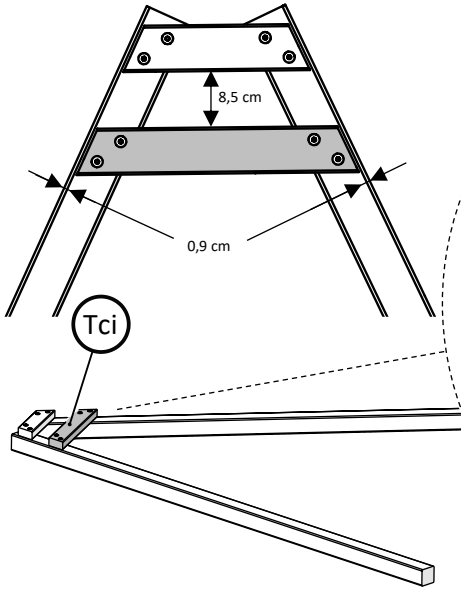

5

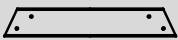

Tci x 2

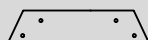

Tch x 2



Vag x 16

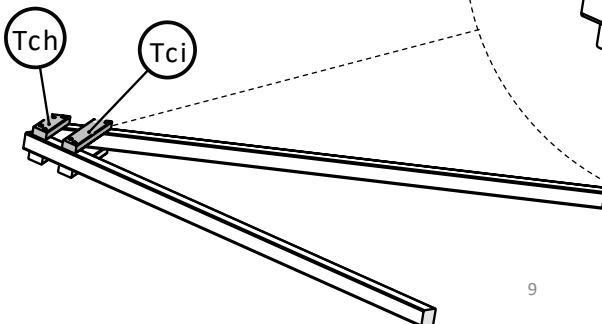
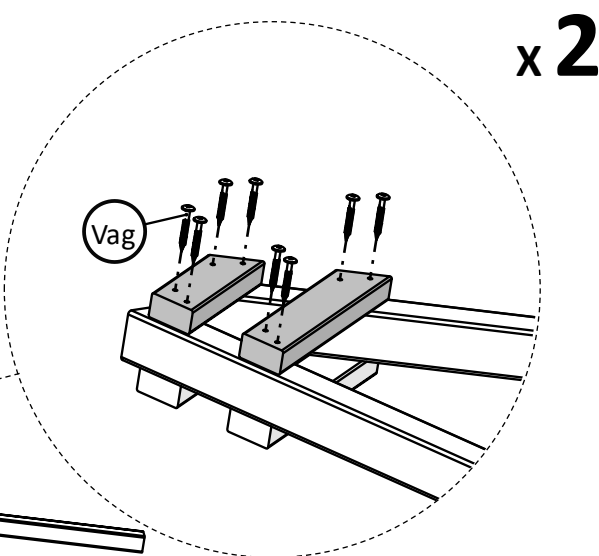
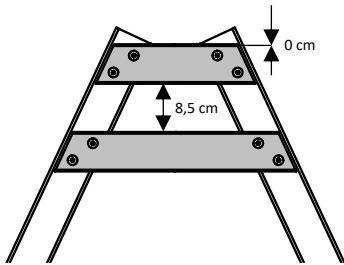

6

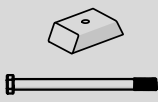

Tcj x 2
Vap x 2



Val x 4
Vam x 4



Van x 2

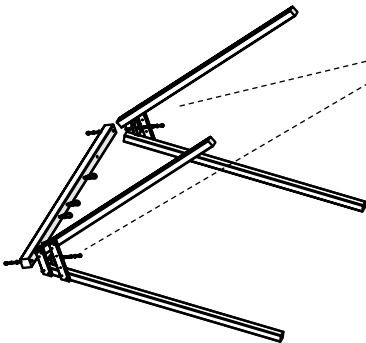
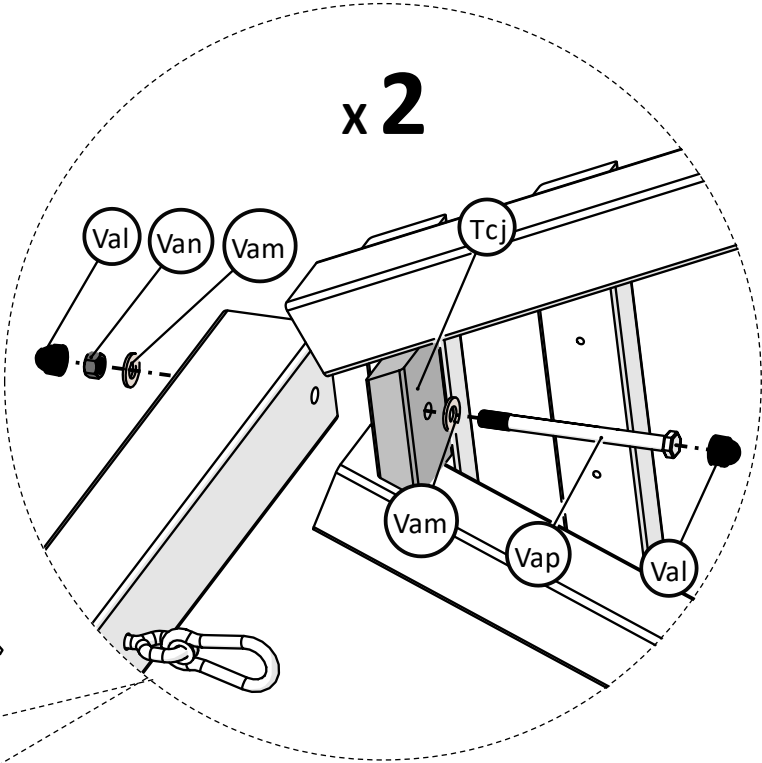
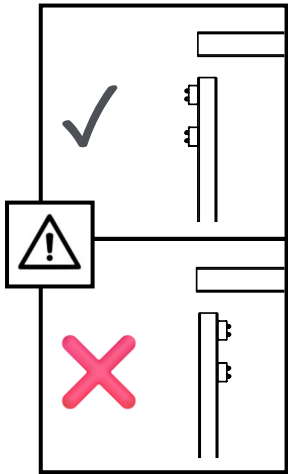
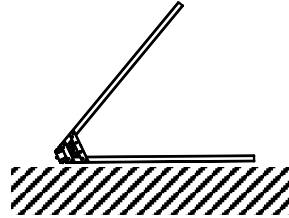
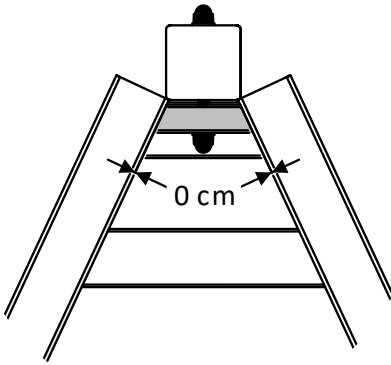

7

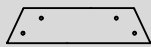

Tch x 2



Vag x 8

Ø6x60 mm

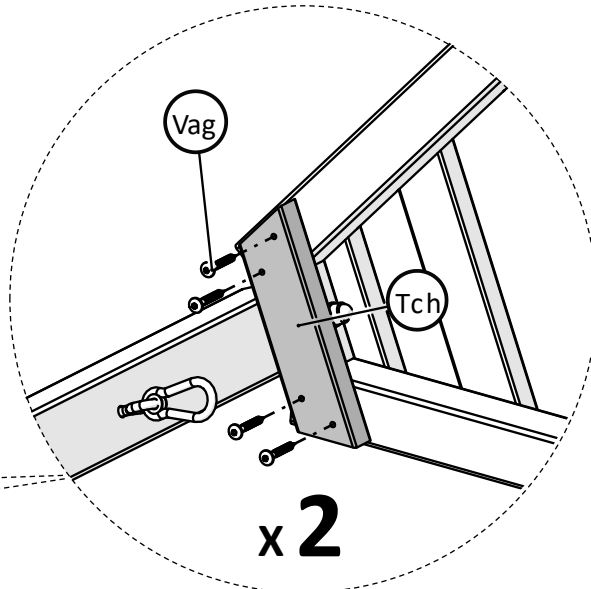
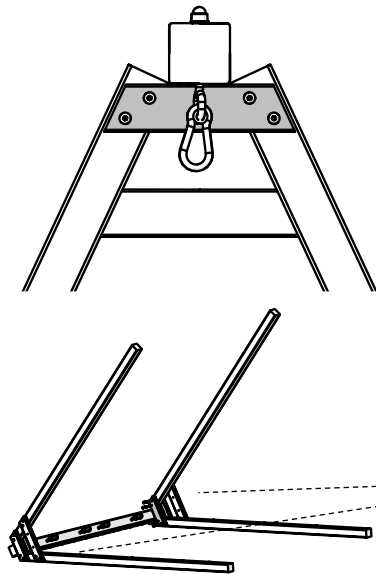

8



Tck x 2



Vaz x 4

Ø6x100 mm



Vau x 4

Ø8x80 mm

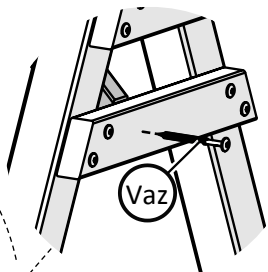
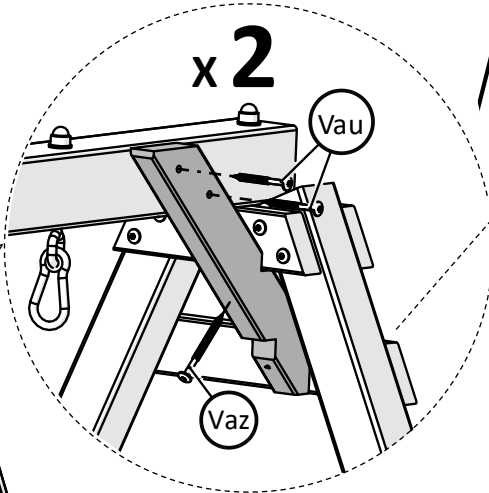
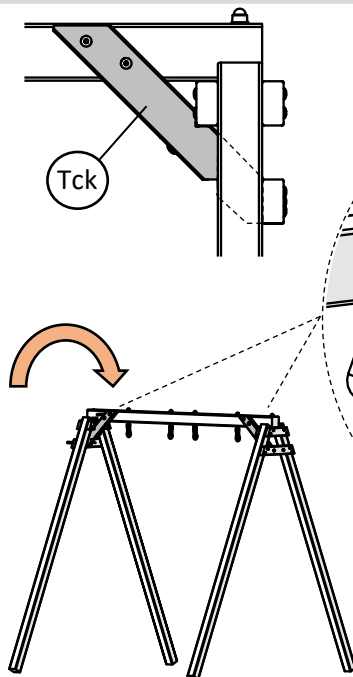

9

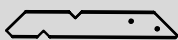

Tck x 2



Ø6x100 mm

Vaz x 4

Ø6x60 mm



Ø8x80 mm

Vau x 4

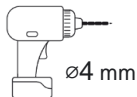

Ø4 mm

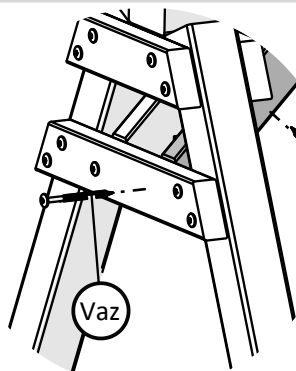

Vau

Vaz

x 2

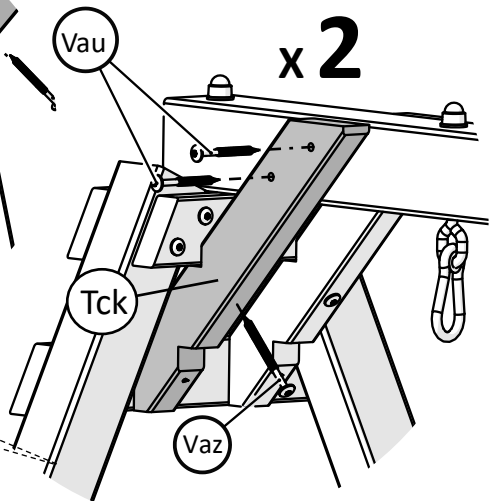

Tck

Vaz

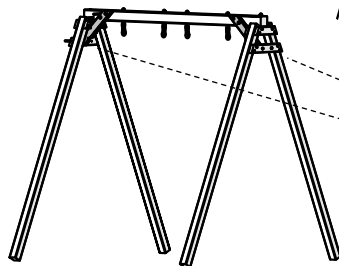

10



Tci x 2



Ø6x60 mm

Vag x 8



Ø6x100 mm

Vaz x 4

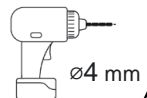

Ø4 mm

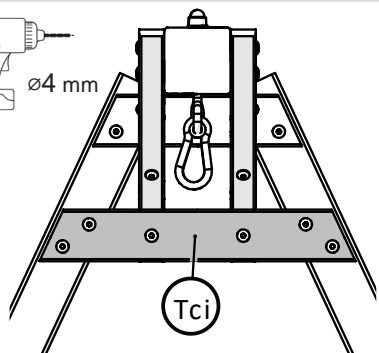

Tci

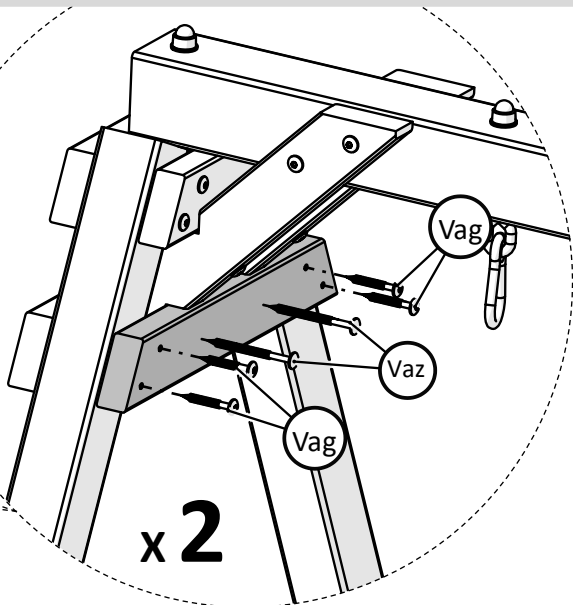
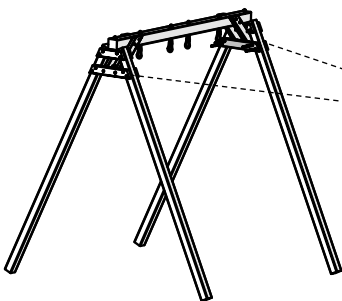

Vag

Vaz

Vag

x 2

11



Lbe x 1



Vaf x 4

Ø5x45 mm

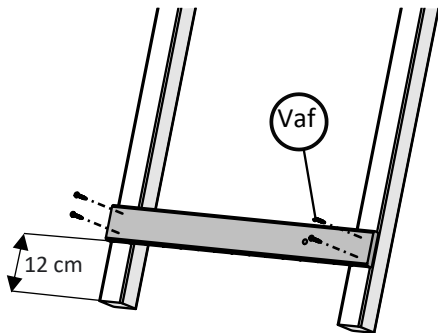
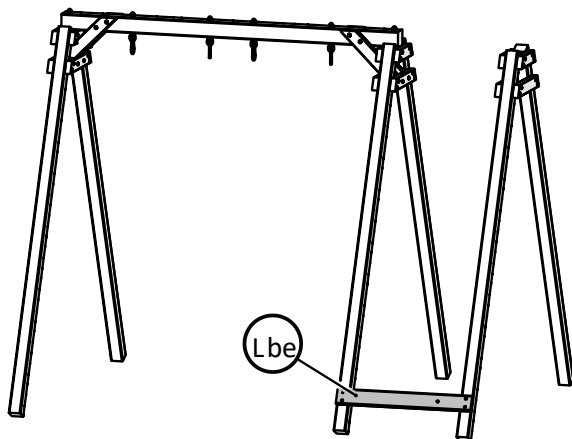

12



Lbe x 9



Vaf x 36

Ø5x45 mm

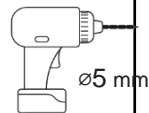
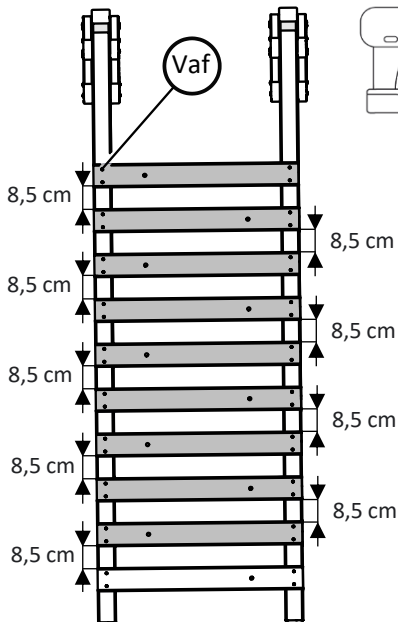
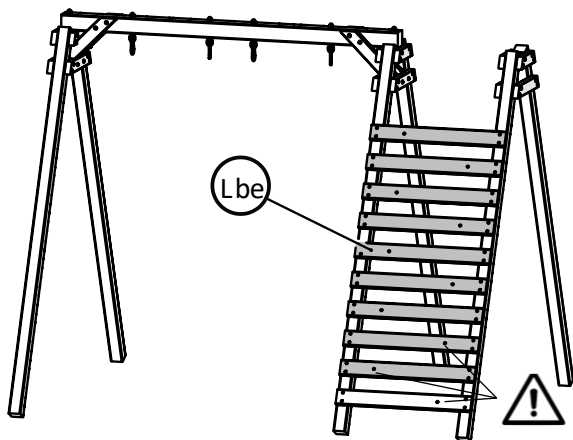

13



Tcn x 2



Vag x 4

Ø6x60 mm

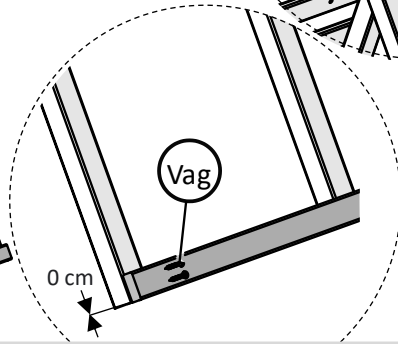
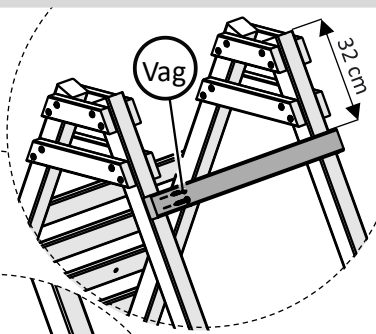
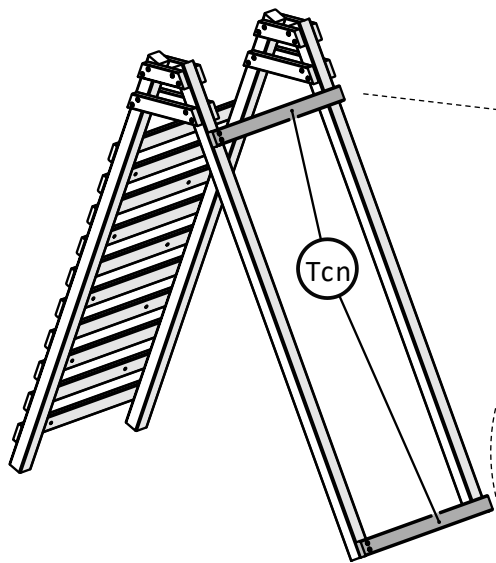

Ø4 mm

14

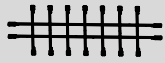

Abn x 1



Vag x 4

Ø6x60 mm

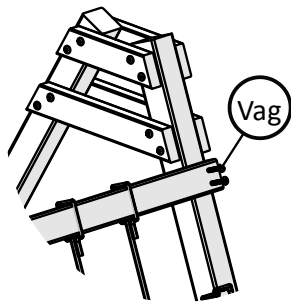
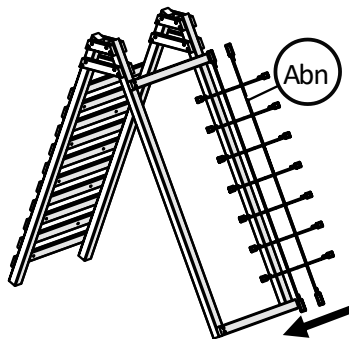

Ø4 mm

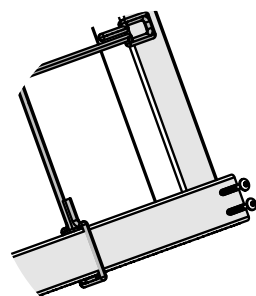
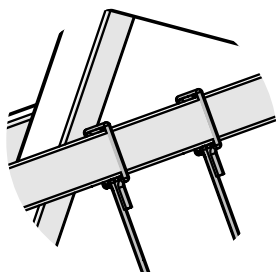
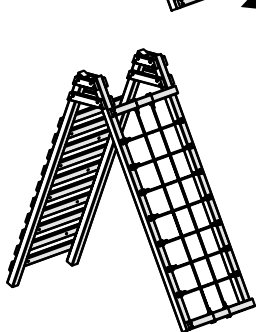



Vav x 14



Vag x 14

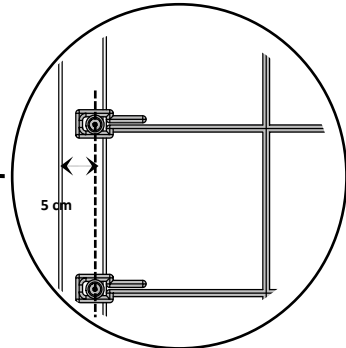
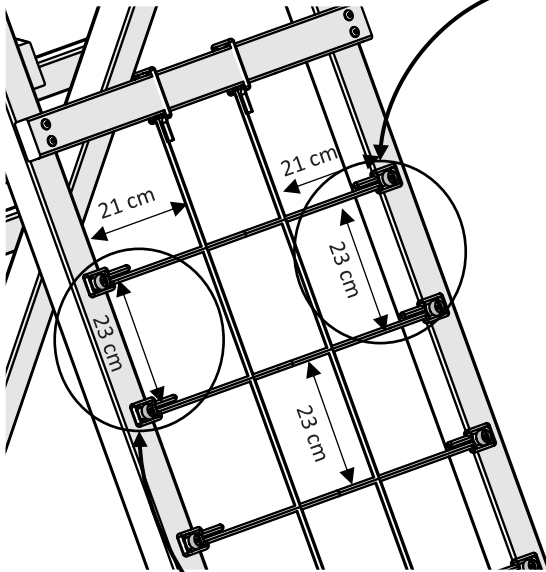
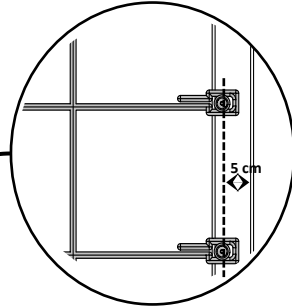
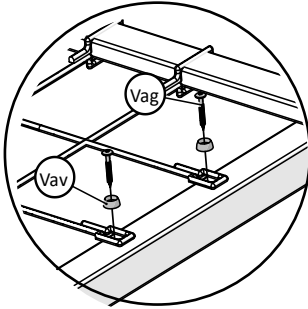

16



Tcn x 1

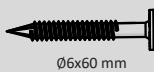

Vag x 4

Ø6x60 mm

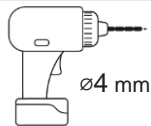

Ø4 mm

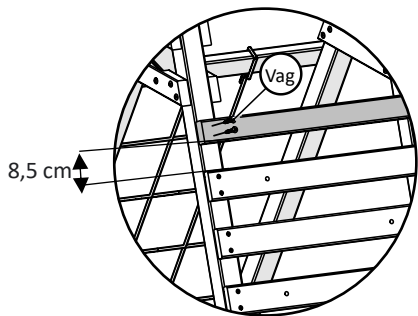
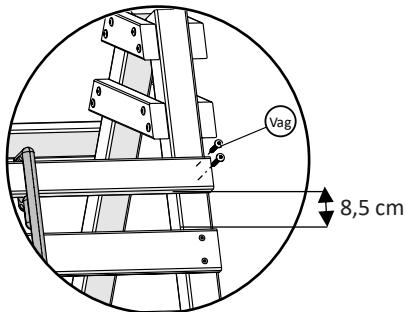
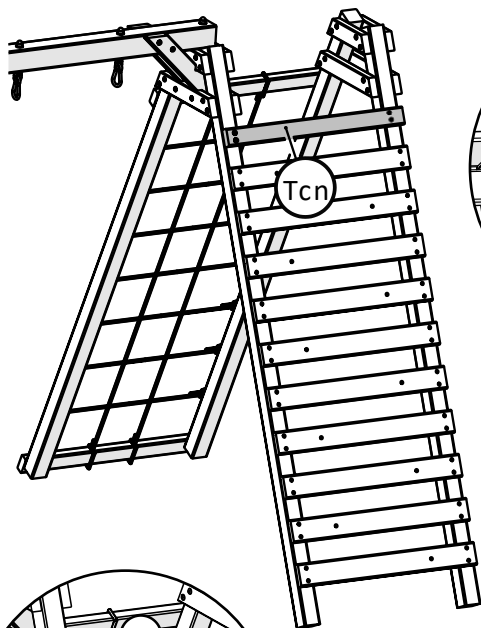



Lbr x 14



Vaf x 4

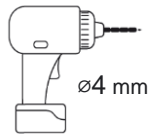

ø4 mm

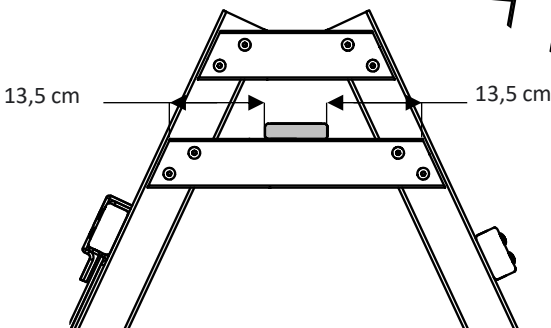
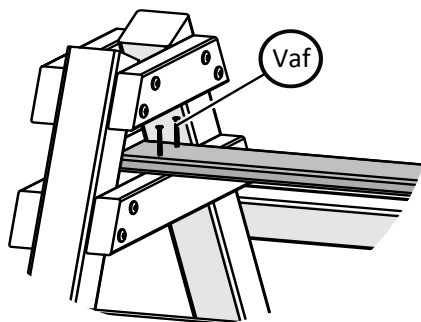
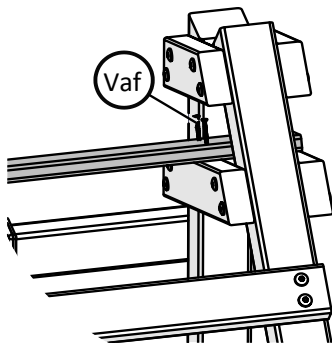
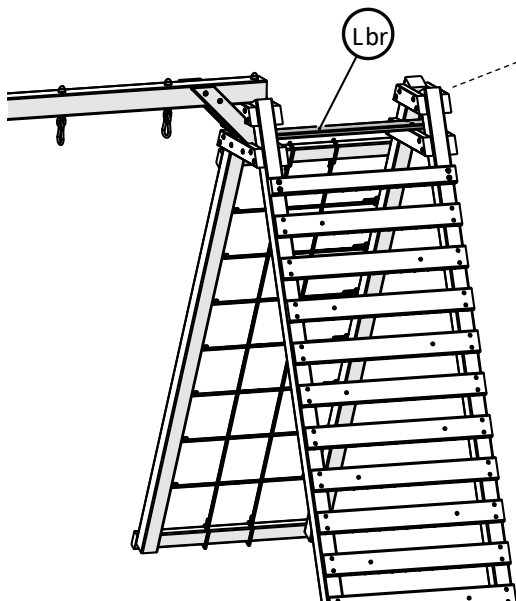
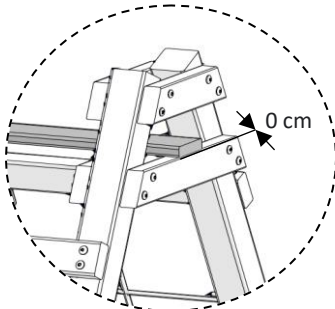



Aaf x 10



Vaj x 10



Vai x 10

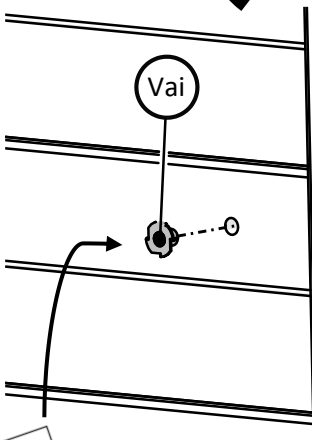

Vai

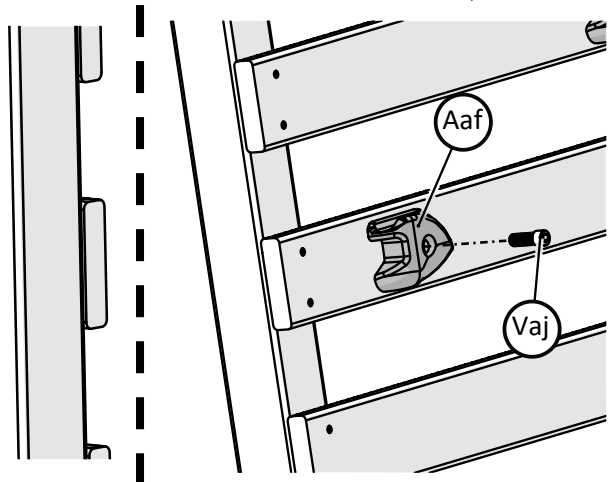

Aaf

Vaj





Tcp x 4



Vaf x 8

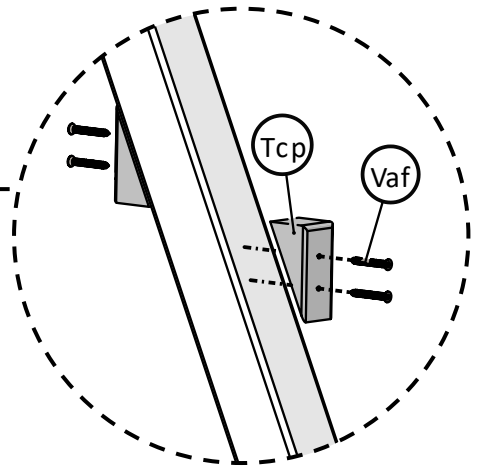
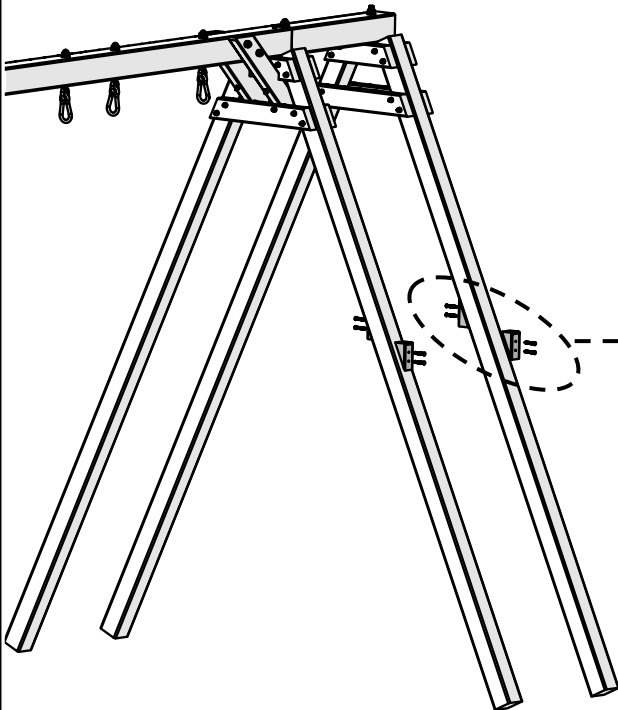
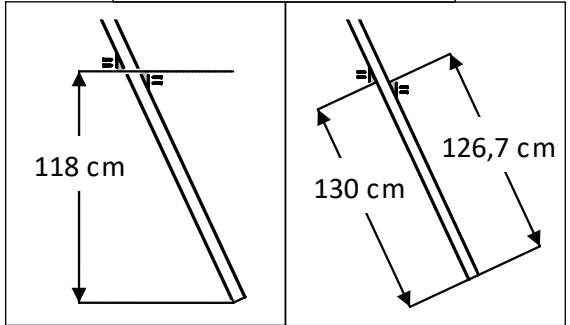
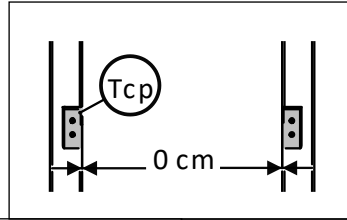

20

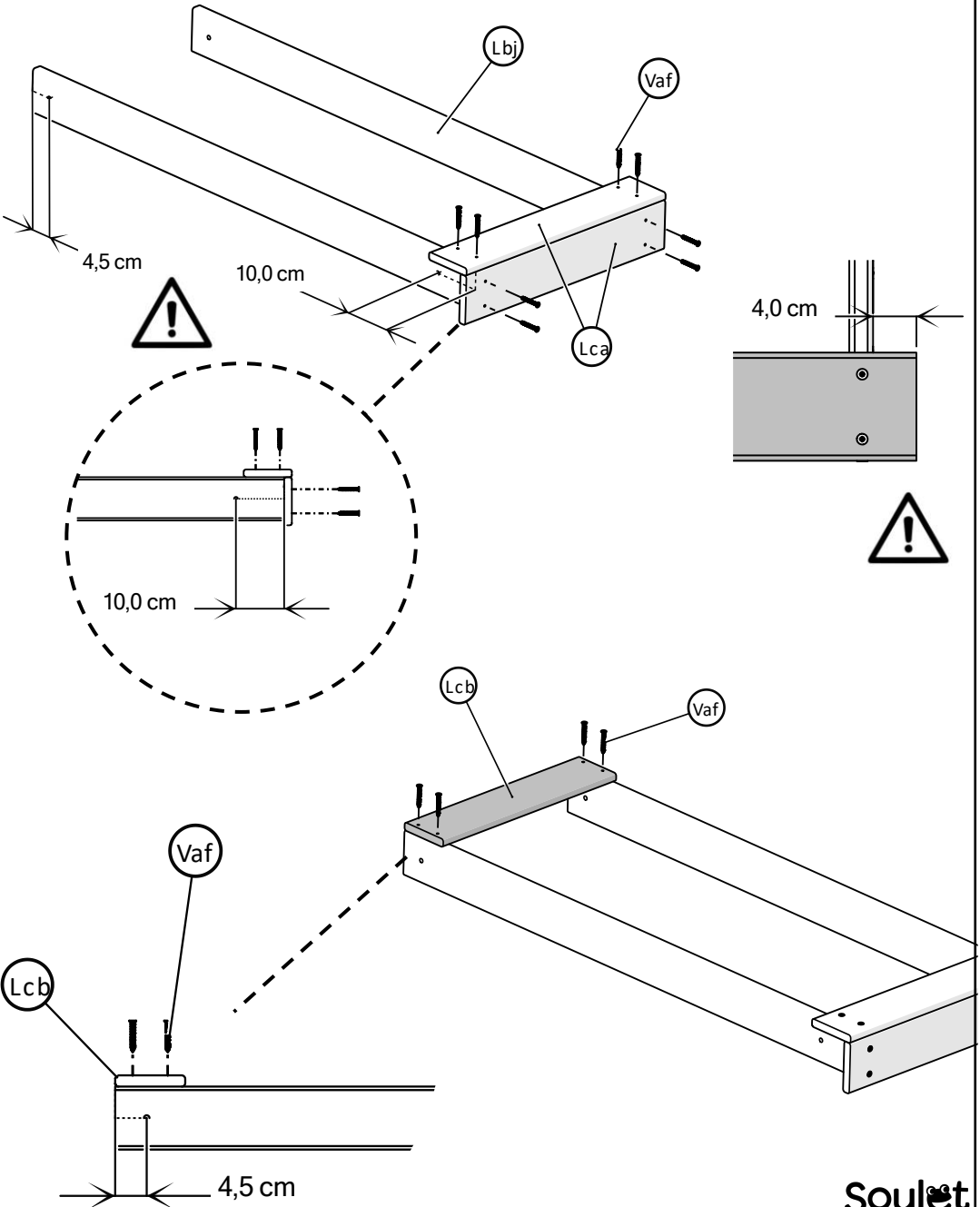
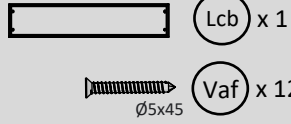
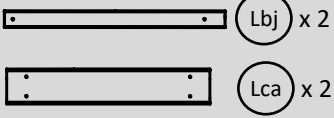



Lcb x 8

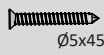

Vaf x 32

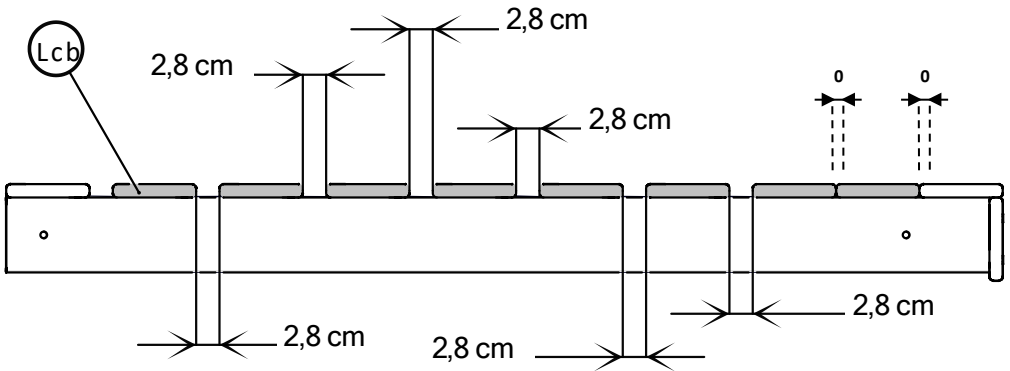
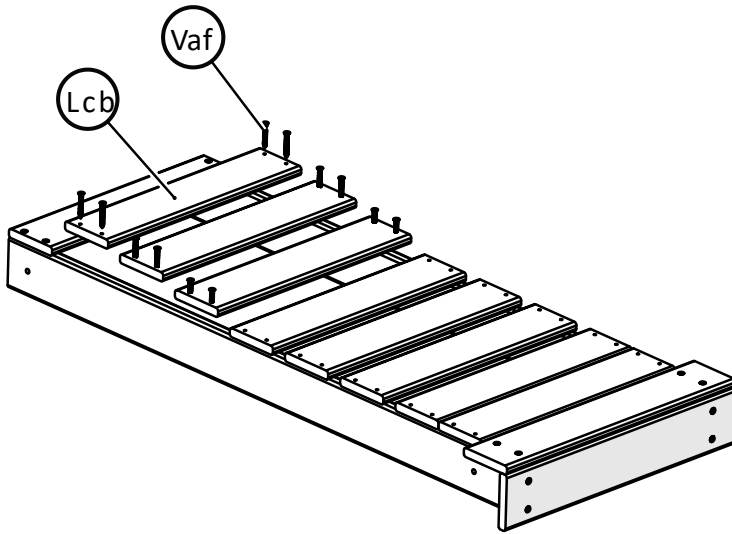

22



x 1

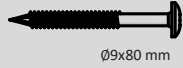

Vau x 4

Ø9x80 mm

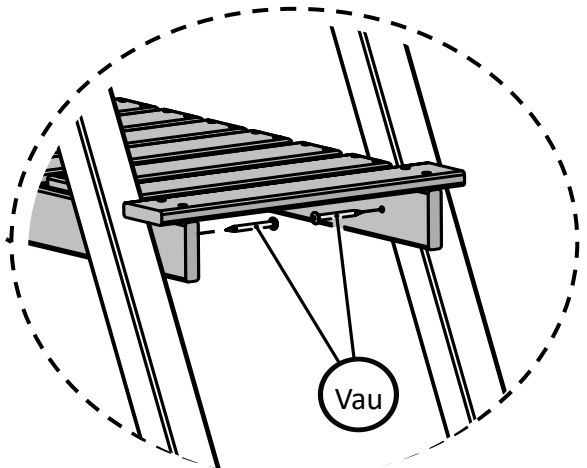
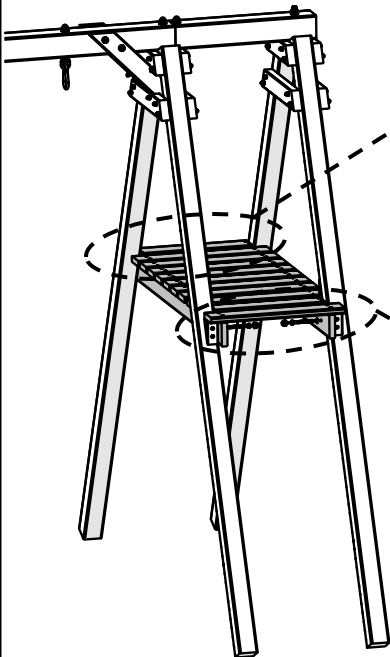
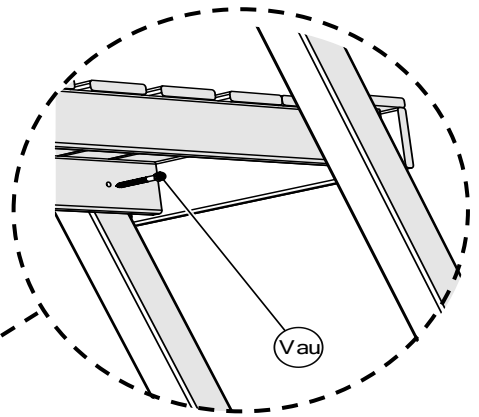
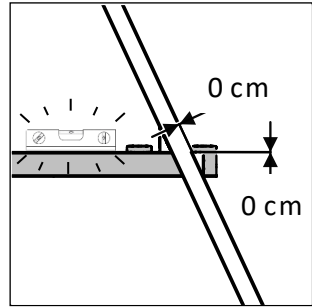
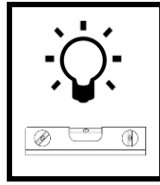
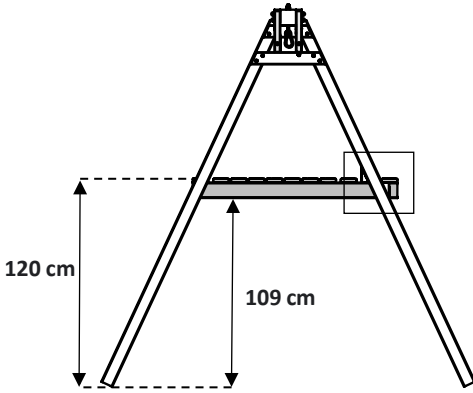









Tbt x 5

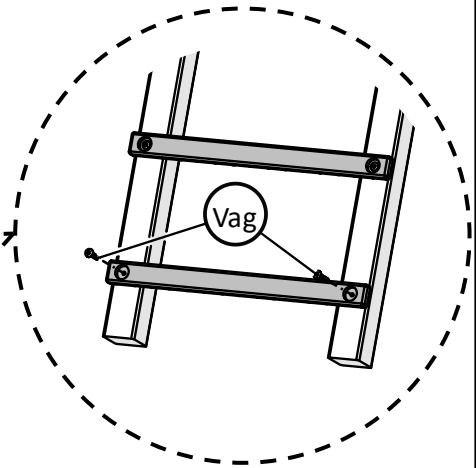
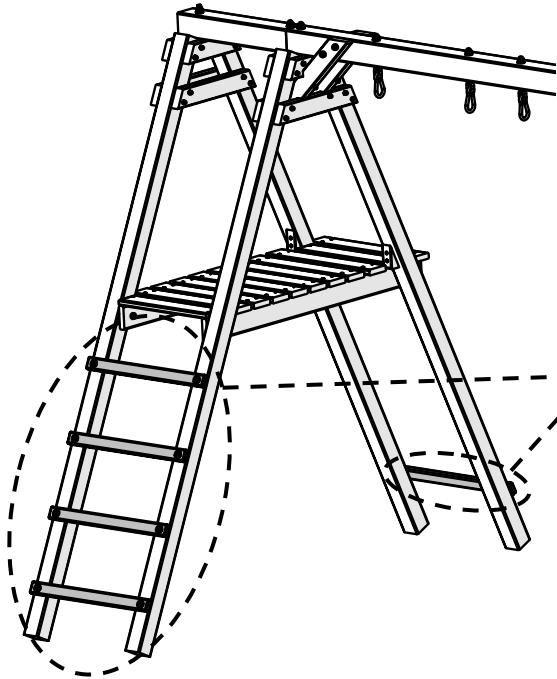
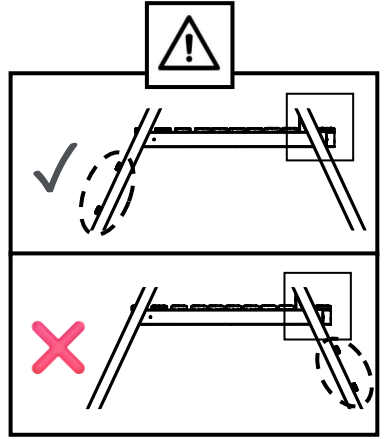
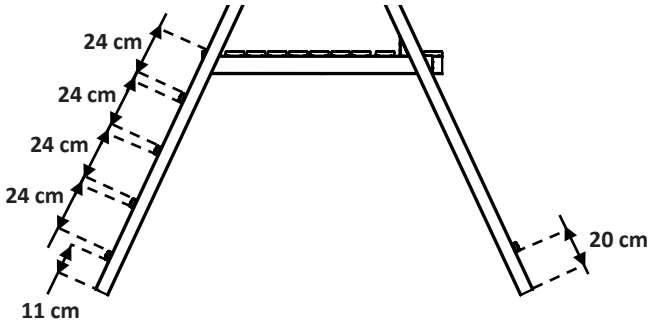

Vag x 10

Ø6x60 mm



-  Lbl x 2
-  Lbn x 2
-  Lbp x 2
-  Lbm x 2
-  Lbo x 2
-  Vaf x 40
Ø5x45 mm

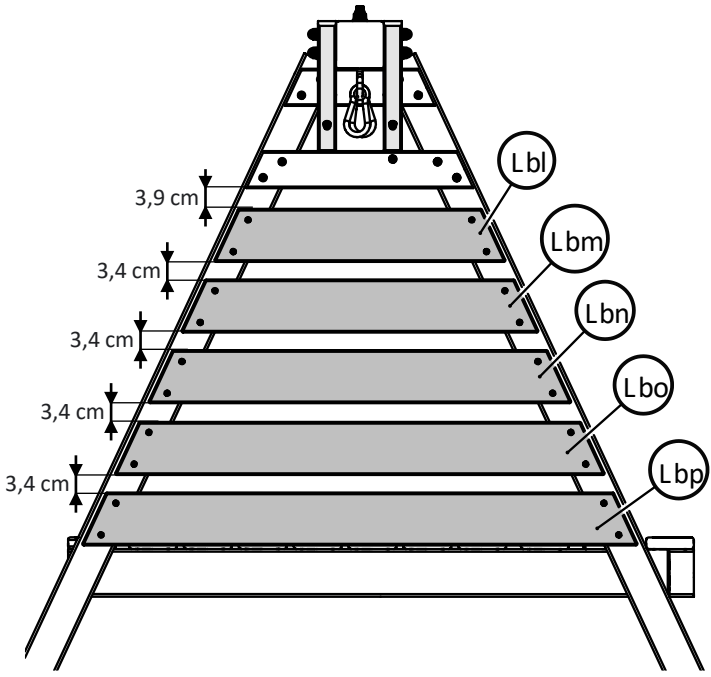
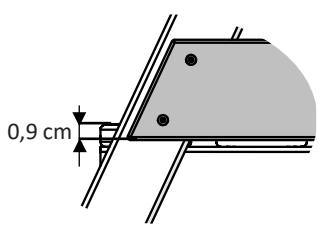
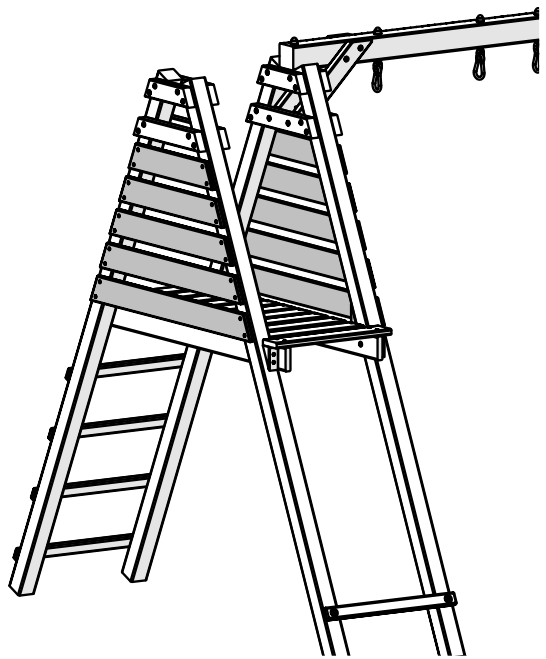
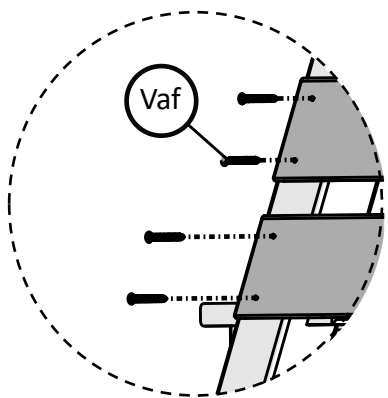



Abt x 1

Ø5 x 30 mm

Vu x 2

Ø5 x 25 mm

Vao x 2

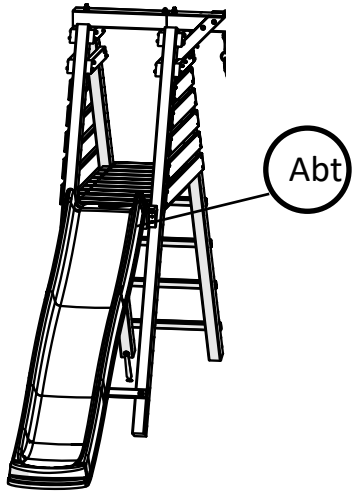

SELON VOTRE MODELE / ACCORDING TO YOUR MODEL

Ø5 x 25 mm

Vao



Vu

Ø5 x 30 mm

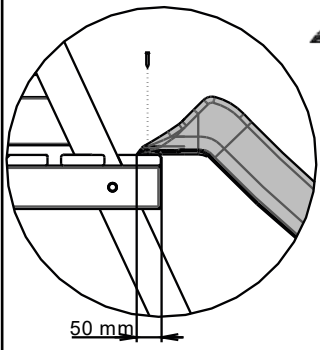

50 mm

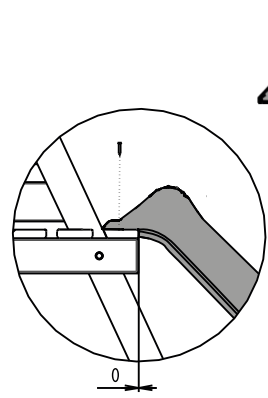
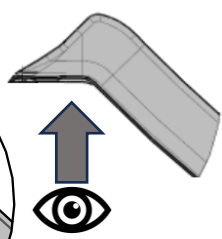

0

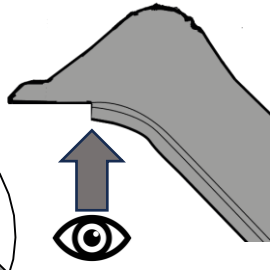

26

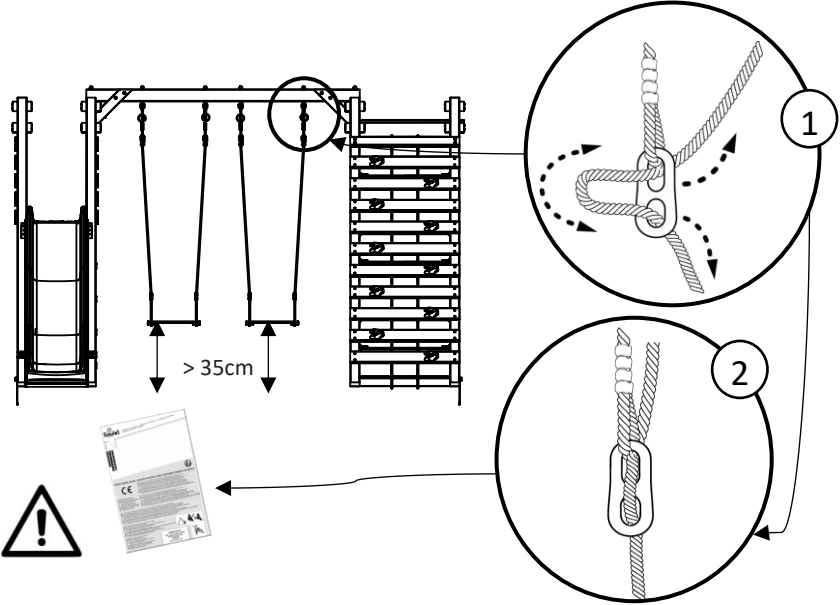
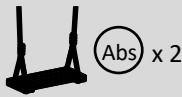

27

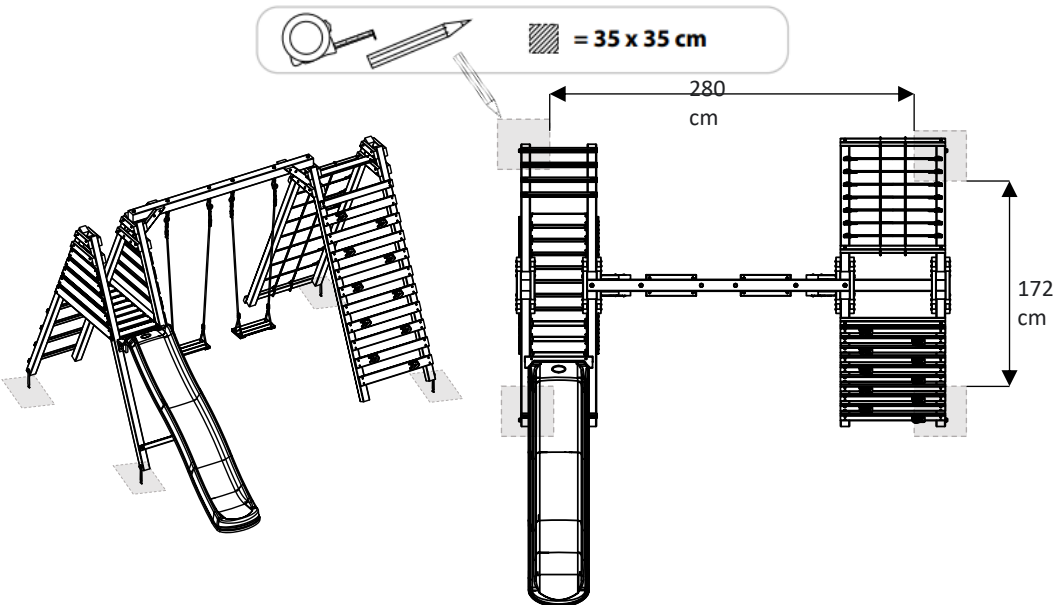

28

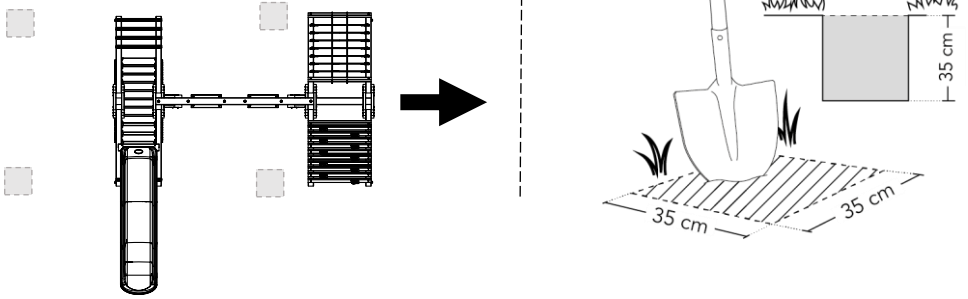

29

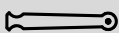
 (Qe) x 4

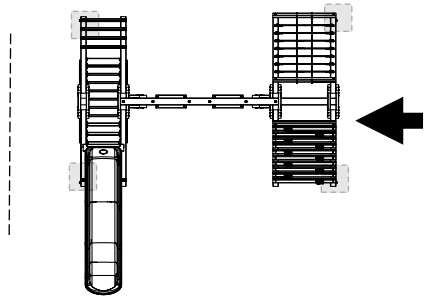
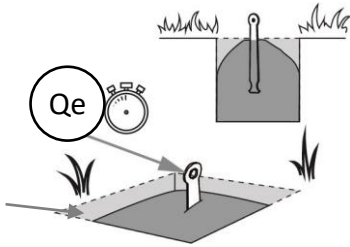

30

 M6

(Vaa) x 4

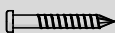
 Ø6 x 50

(Vab) x 4

 M6

(Vz) x 4

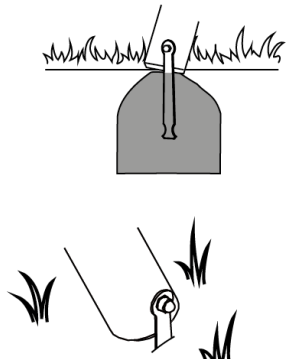
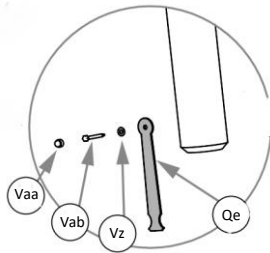
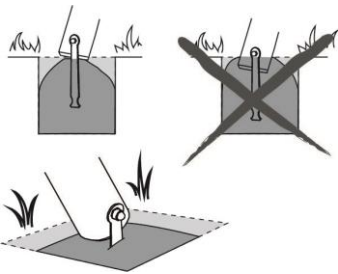

Soulet

FUN SINCE 1846

N° de lot / Batch N° :



service.client@soulet.com