

Dallas

Class 1
 E27

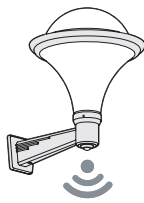

x1

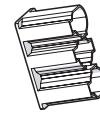

x1

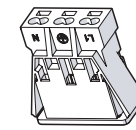

x1



x3



x4



x3

1 Fixation murale Fix to the wall

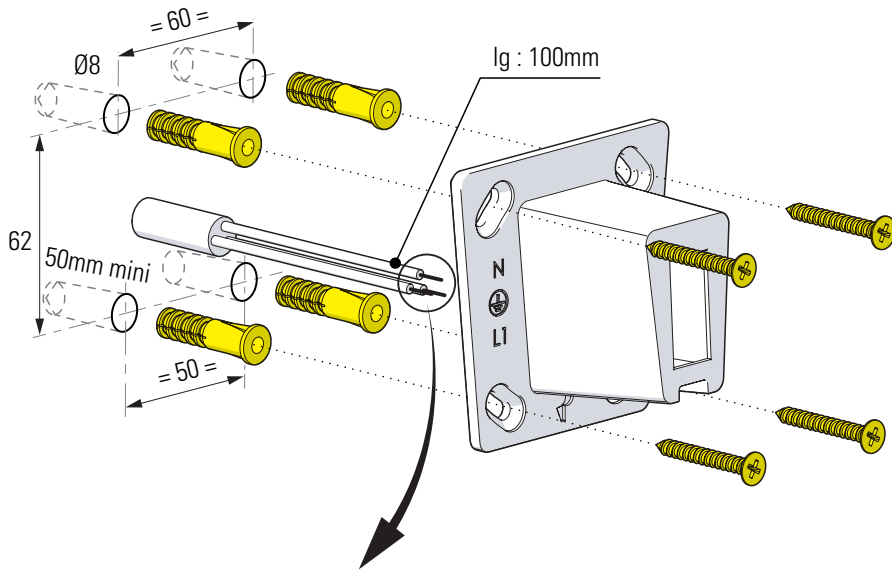

2 Raccordement électrique Connect electrical wires

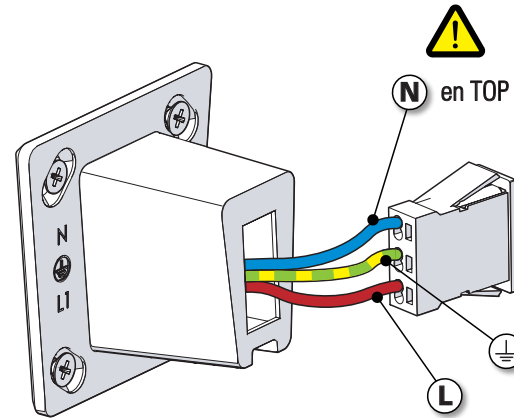

3 Montage du connecteur Put in place connector

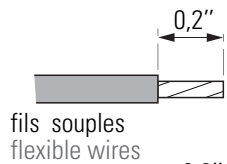
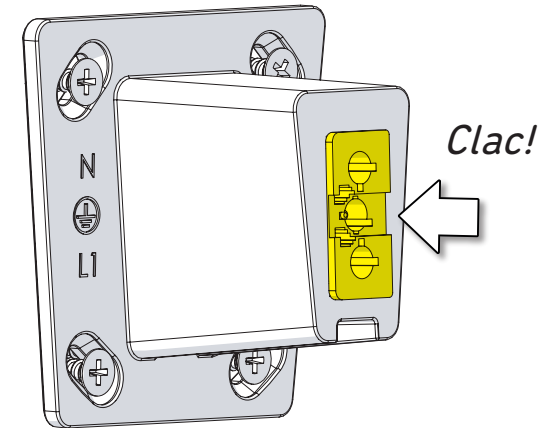

fils souples
 flexible wires

Sertir les embouts sur les fils
 Crimp the wire ferrules

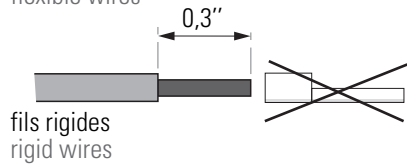

fils rigides
 rigid wires

Pas d'embout
 No wire ferrule

4 Montage de la lampe
Install the light bulb

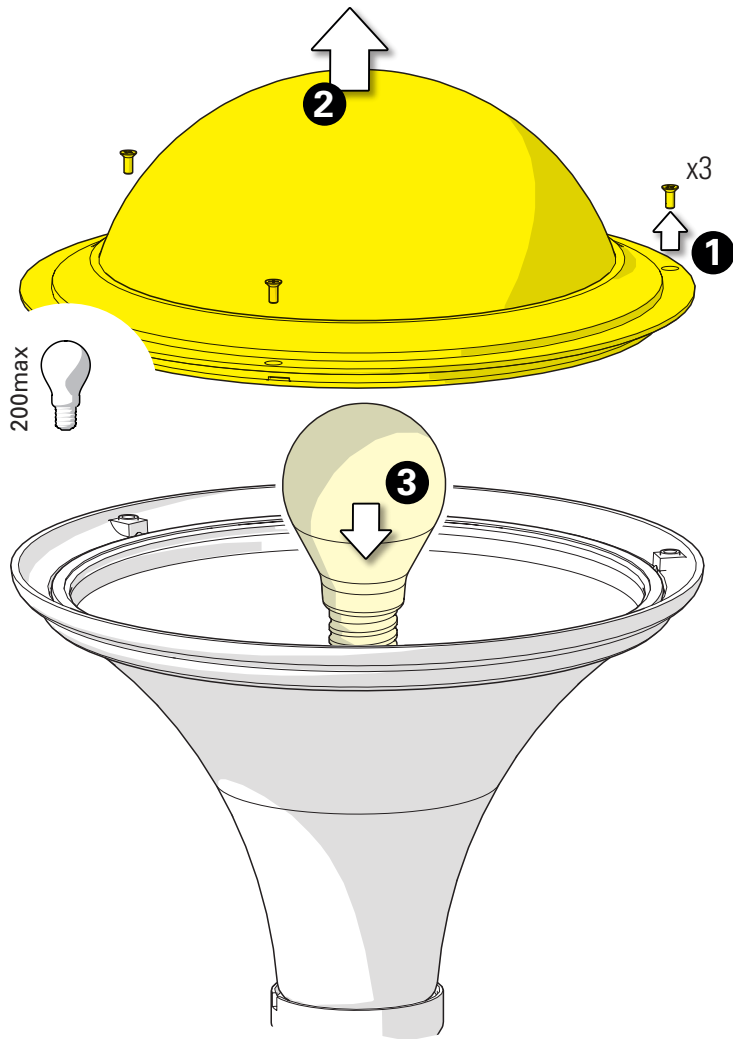

5 Fermeture de la lanterne
Close the luminaire

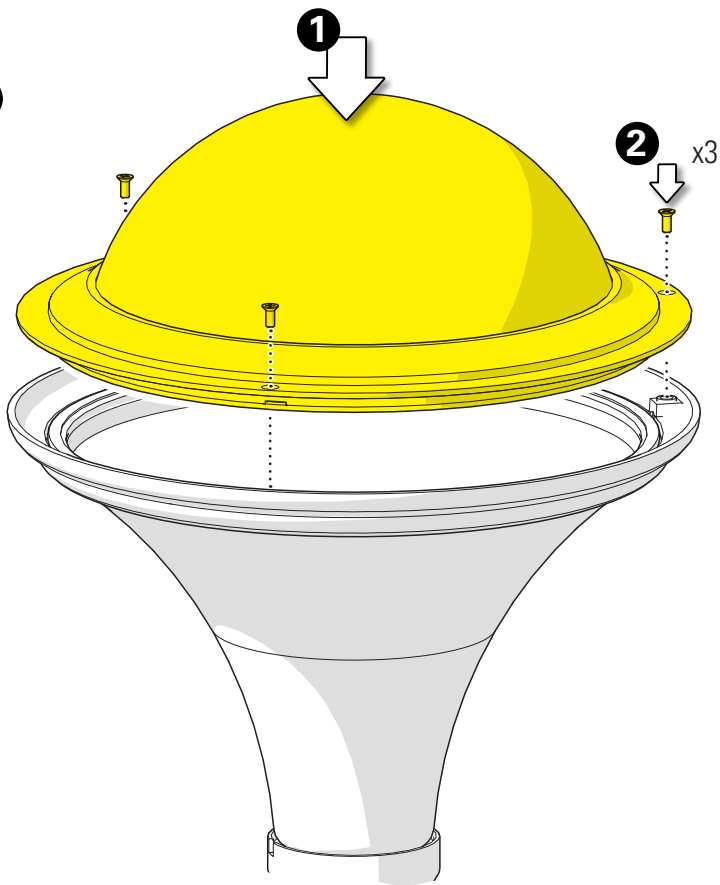

6 Montage du luminaire & serrage de la vis de blocage
Assemble the luminaire & tighten the locking screw

