

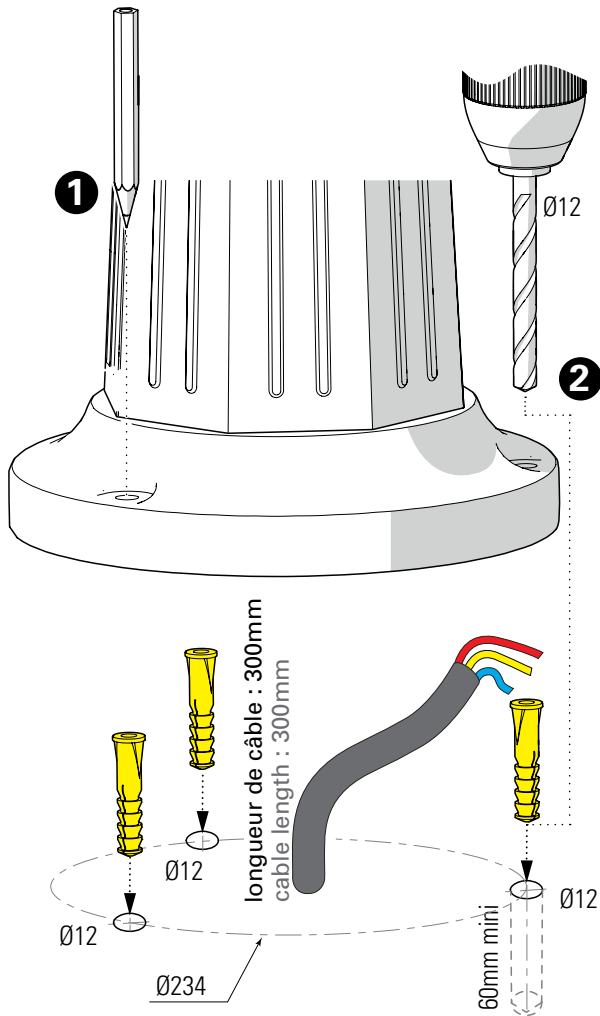

Class 1
 E27



1 Traçage et perçage des trous de fixation Trace and drill the mounting holes



2 Montage du groupement sur le mât Mount the head assembly on the mast

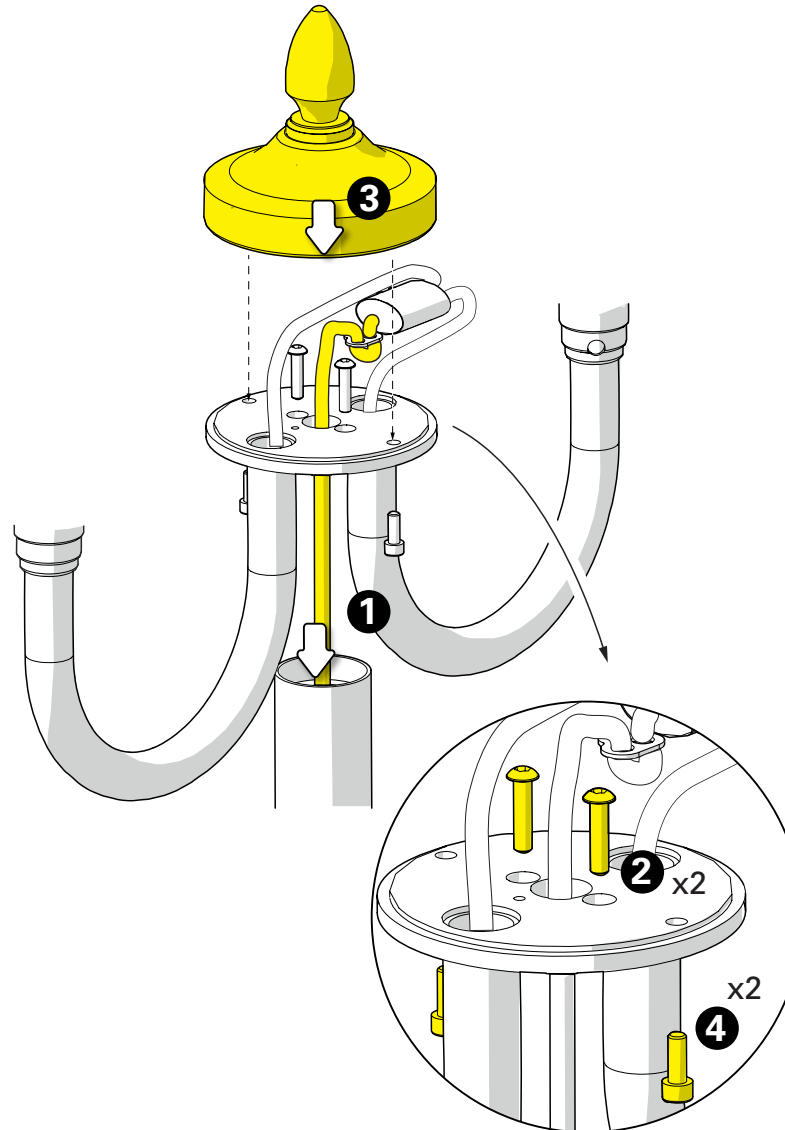

3 Raccordement électrique Connect electrical wires

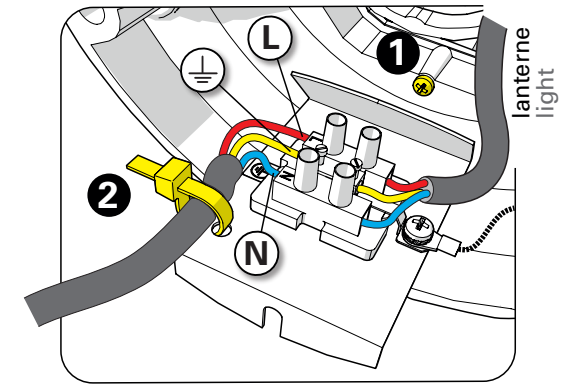

4 Fixation du luminaire
Fix the luminaire

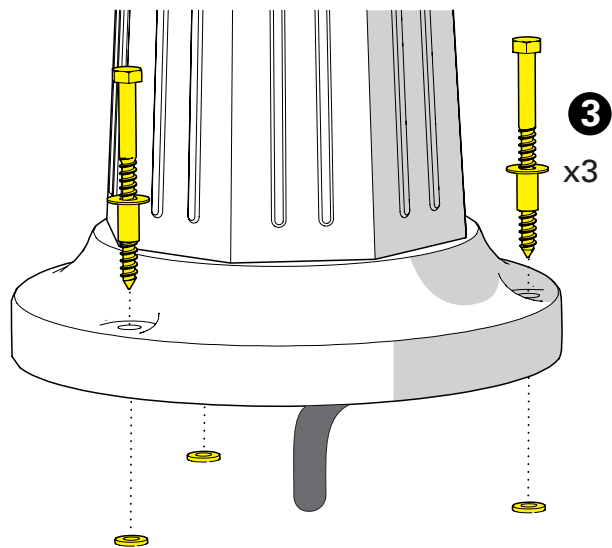

5 Réglage hauteur du mât
Set up the mast height

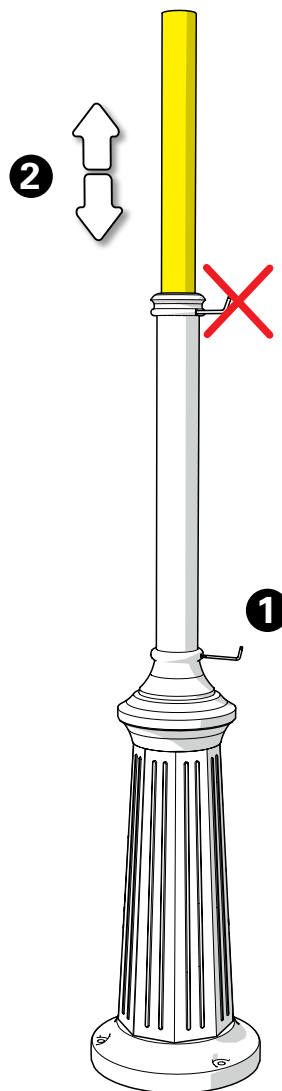

6 Montage de la lampe & du globe
Install the light-bulb & the globe

