

1 Traçage & perçage des trous de fixation
 Trace & drill the mounting holes

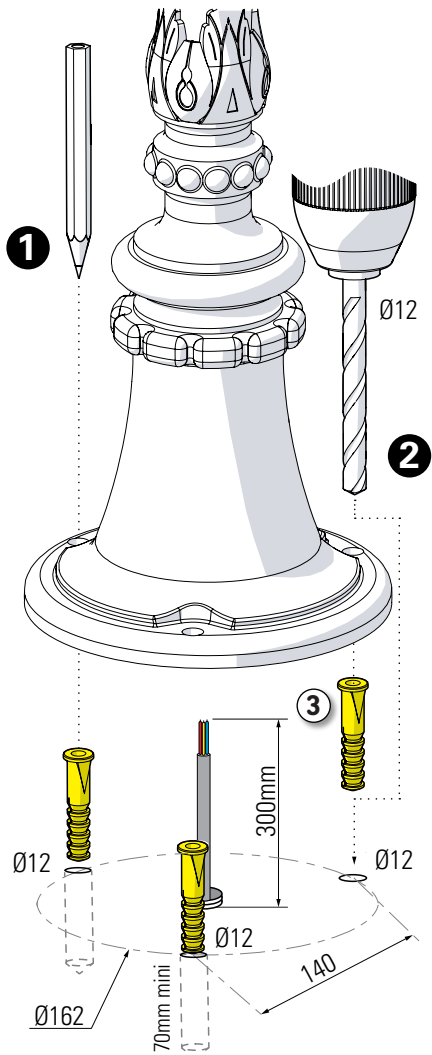

2 Raccordement électrique
 Connect electrical wires

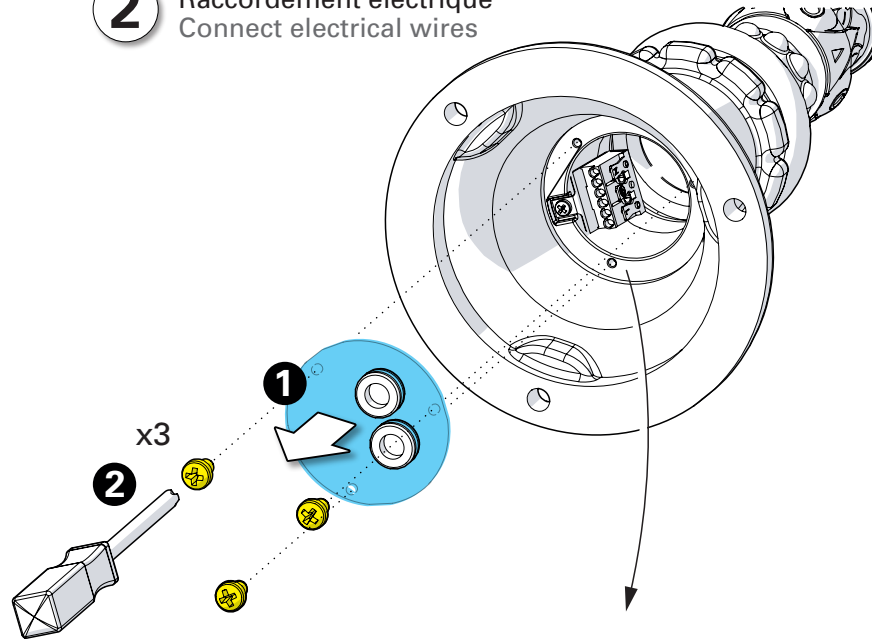

3 Fermeture du boîtier de connexion
 Close the connection box

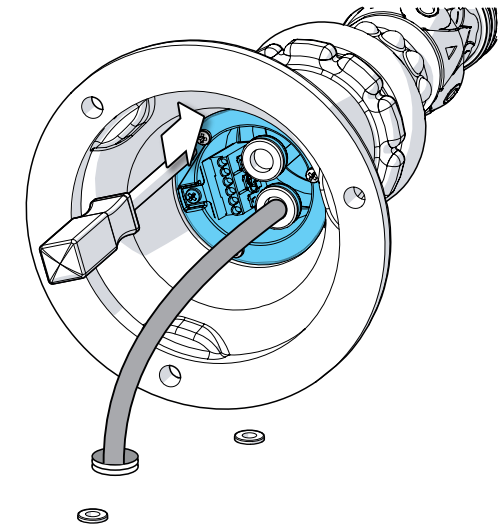

x3 Ø2mm

ou

x1 Ø4mm

⚠
 Respecter l'étanchéité!
 Beware of the perfect sealing

percer à la pointe
 pierce with nail

4

3

4 Fixation du luminaire
Fix the luminaire

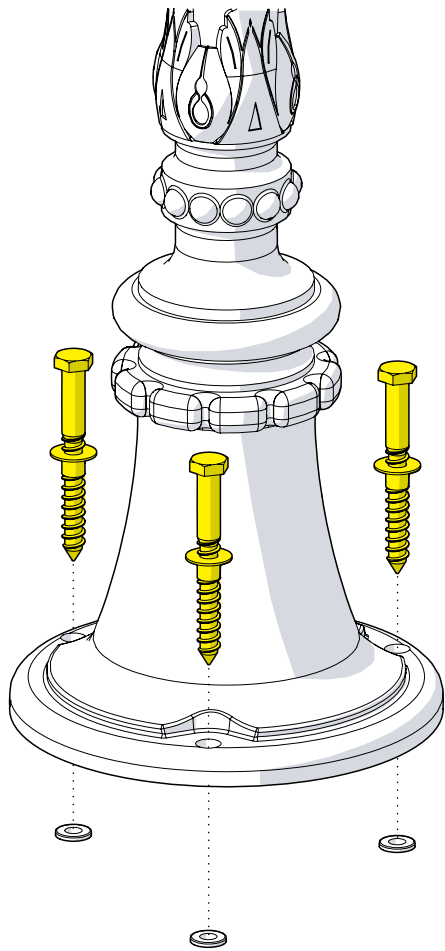

5 Montage de la lampe & des verres
Put in place the light-bulb & the glasses

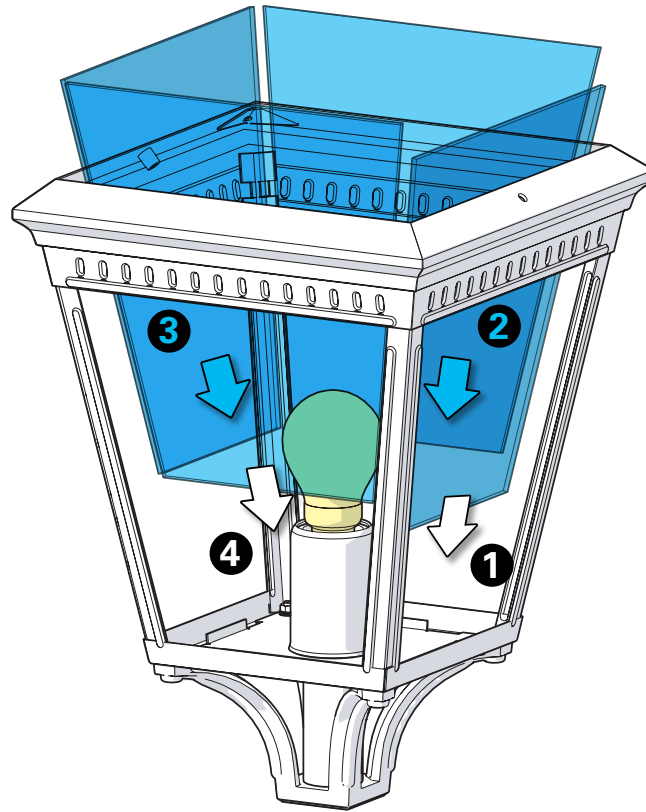

6 Montage du chapiteau
Assemble the dome

