

1 Traçage & perçage des trous de fixation
 Trace & drill the mounting holes

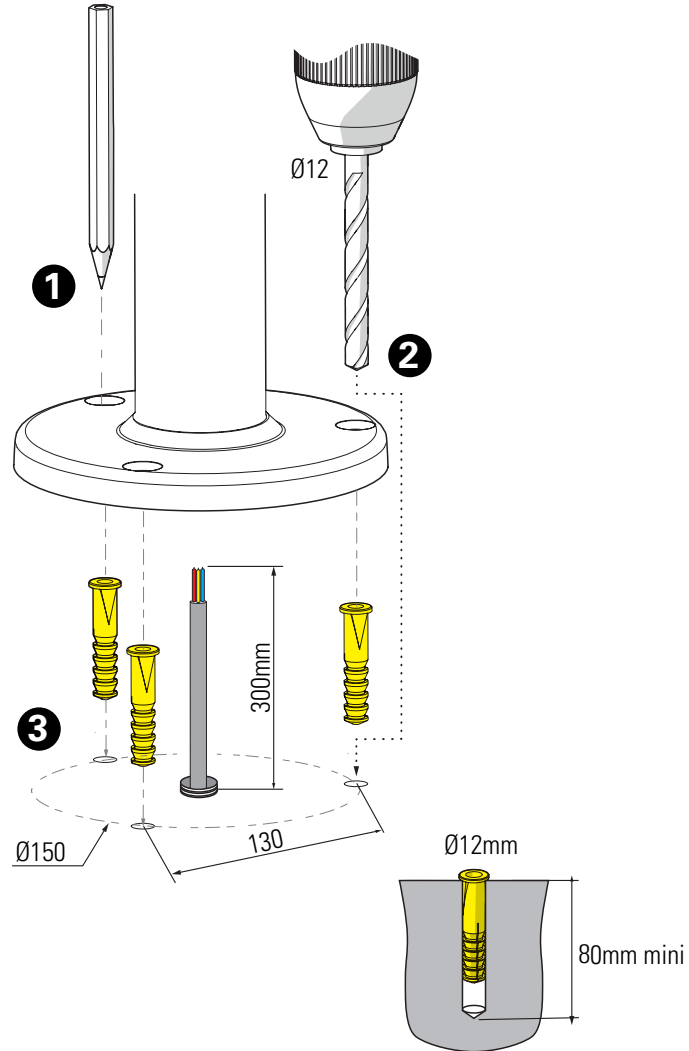

2 Montage du bras
 Assemble the bracket

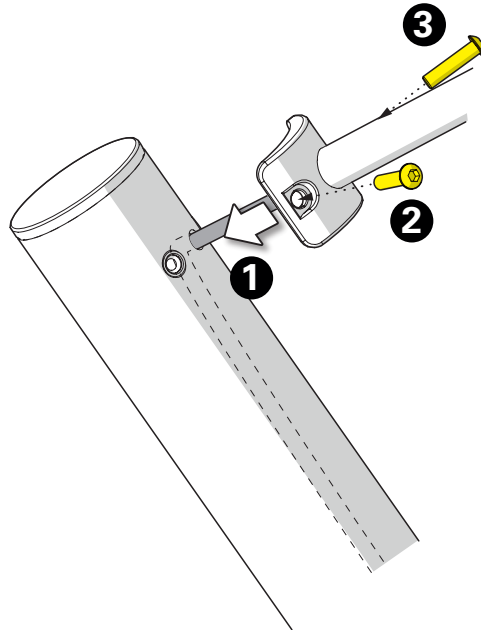

3 Raccordement électrique
 Connect electrical wires

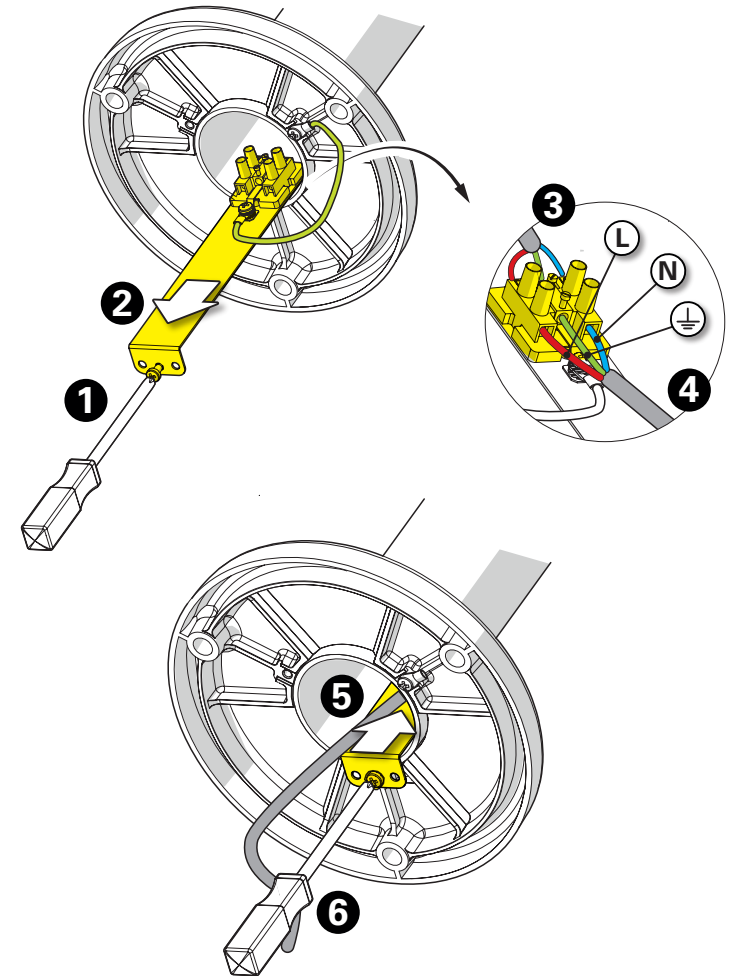

4 Fixation du luminaire
Fix the luminaire

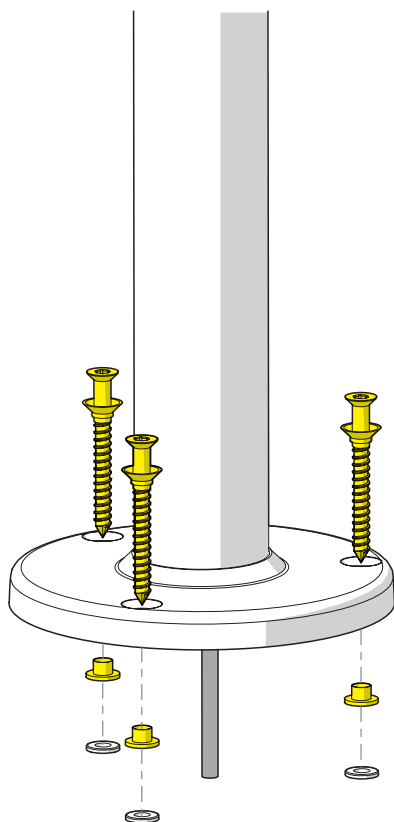

5 Montage de la lampe
Install the light-bulb

