

- 1** Scellement des tiges & fixation du mât
 Install anchor J-Bolts in concrete foundation & fix the mast

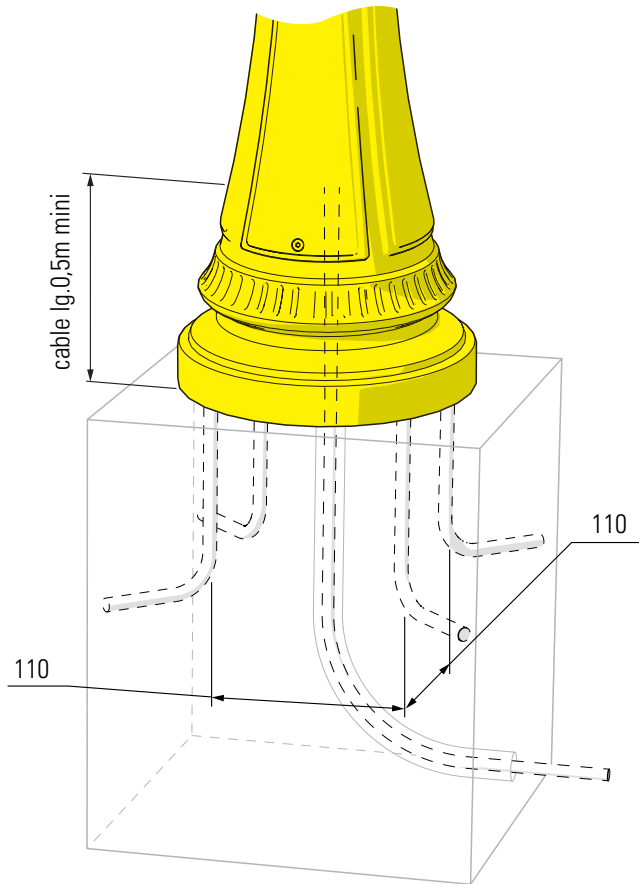

- 2** Montage de la tête sur le mât
 Mount the luminaire head on the mast

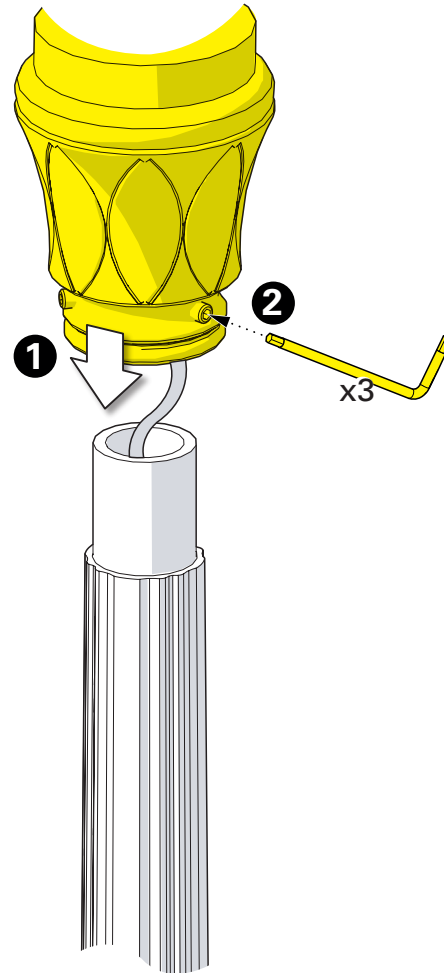

- 3** Raccordement électrique
 Connect electrical wires

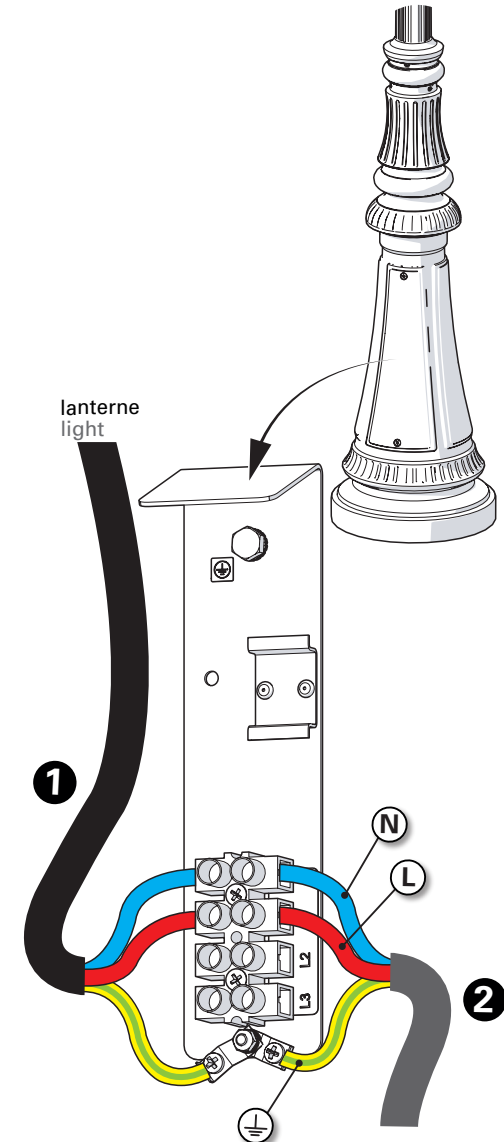

- 4** Montage de la lampe & des verres
Put in place the light-bulb & the glasses

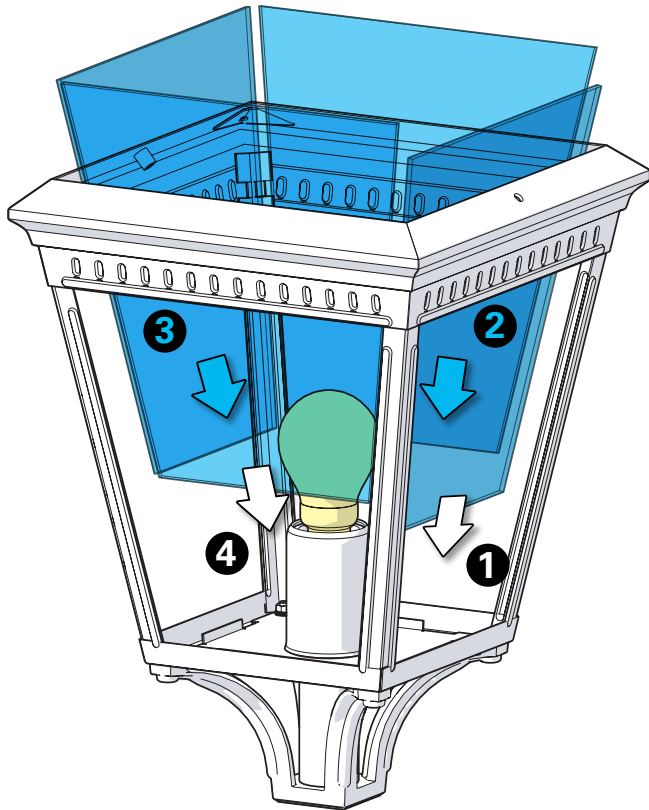

- 5** Montage du chapiteau
Assemble the dome

